



# 三菱工業用ミシン部品カタログ

## Industrial Sewing Machine Parts Catalog

Model LT2-2240-M0B  
 LT2-2240-B0B  
 LT2-2250-M1TW  
 LT2-2250-A1T  
 LT2-2250-B1T

目次	CONTENTS	Page
A 本体部分	Body & it's accessories .....	2
B 上糸調節器部分(国内用)(I)	Thread tension regulator mechanism (Domestic only) (I) .....	4
C 上糸調節器部分(輸出用)(II)	Thread tension regulator mechanism (Export only) (II) .....	6
D 上軸・押え・ひざ上げ機構	Upper shaft & presser foot mechanism .....	8
E 天秤・針棒揺動機構	Thread take-up lever & needle bar rock motion mechanism .....	10
F 針棒機構	Needle bar mechanism .....	12
G 針棒切換機構	Needle bar changing mechanism .....	14
H 縫目加減機構	Stitch regulator mechanism .....	16
J 下軸・送り機構	Lower shaft & feed rock shaft mechanism .....	18
K カマ台機構	Hook saddle mechanism .....	20
L 糸切り機構(I)	Knife mechanism (I) .....	22
M 糸切り機構(II)	Knife mechanism (II) .....	24
N タッチバックおよび検出器機構	Touch back, compensation stitching & detector mechanism .....	26
P ワイパー機構	Wiper mechanism .....	28
Q 給油機構	Oil lubrication mechanism .....	30
R 付属品	Accessories .....	32
S ゲージ部品表(I)LT2-2240	Gauge parts list (I) .....	34
T ゲージ部品表(II)LT2-2250	Gauge parts list (II) .....	36
索引	Index .....	38

# ミシン用部品コードの採番基準

## MITSUBISHI SPARE PARTS No. Designation system

注:※欄には英文字 (A,B,...X,Y,Z) が入る。  
Remarks: Alphabet (A,B,...X,Y,Z) should be taken at ※ mark.

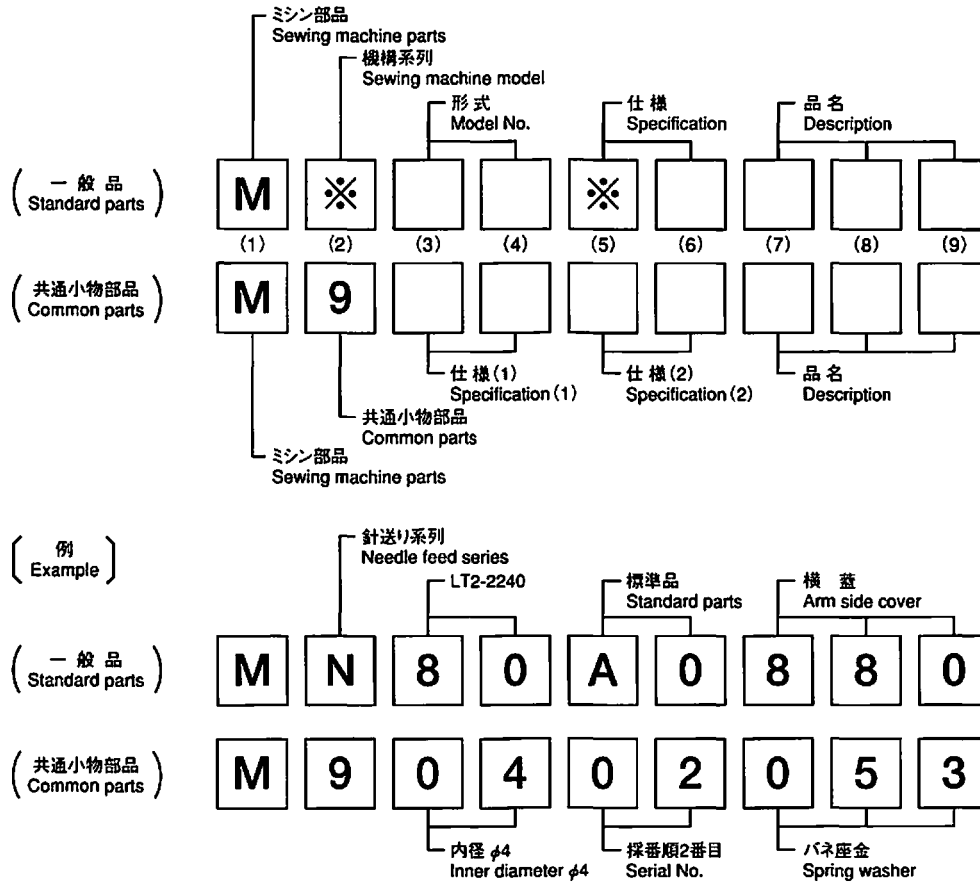

注: 一般品についての機種形名は、その部品が最初に使用された機種形名を示します。従って長期に亘る場合は、機種  
の改良が行われるため、当初の機種以外の機種で使用されている場合があります。  
Sewing machine Models, of Standard Parts are indicated model of these parts are registered firstly. Parts  
are used for not only the indicated model, but also another models, in reason of New development,  
improvement after.

### パーツカタログご利用に際して Information on use of the parts catalog

- ・補用部品ご注文の際は、部品コードでご注文ください。また、このパーツブックの管理番号とモデル機種番号を、合わせてご連絡頂ければ幸いです。
  - ・一部の部品について、改良のため予告なしに変更になる場合がありますのでご了承ください。
  - ・部品コード欄が、—となっている部品は、補給いたしません。ただし組コードが記載されているものは、組部品として補給いたしますので、組コードでご注文ください。
  - ・使用個数欄の英数字組合せ文字は、このモデル番号のサブ機種番号をしめています。
  - ・尚、本パーツブックの記載内容にお気付きの点がありましたら、お知らせ頂ければ幸いです。
- ・When ordering any spare part, please specify its part code. In addition, please specify the management number and the machine model number.
  - ・Some parts are subject to change due to modification without notice.
  - ・Any part marked-in the part code column will not be supplied. When a part has its assembly code, please specify the assembly code because that part is supplied as an assembly part.
  - ・Alphanumerical characters indicated in the required quantity column indicate the sub machine number of this model number.
  - ・Please write to us if you have any question on this parts catalog.

☐ 本体部分  
BODY & IT'S ACCESSORIES

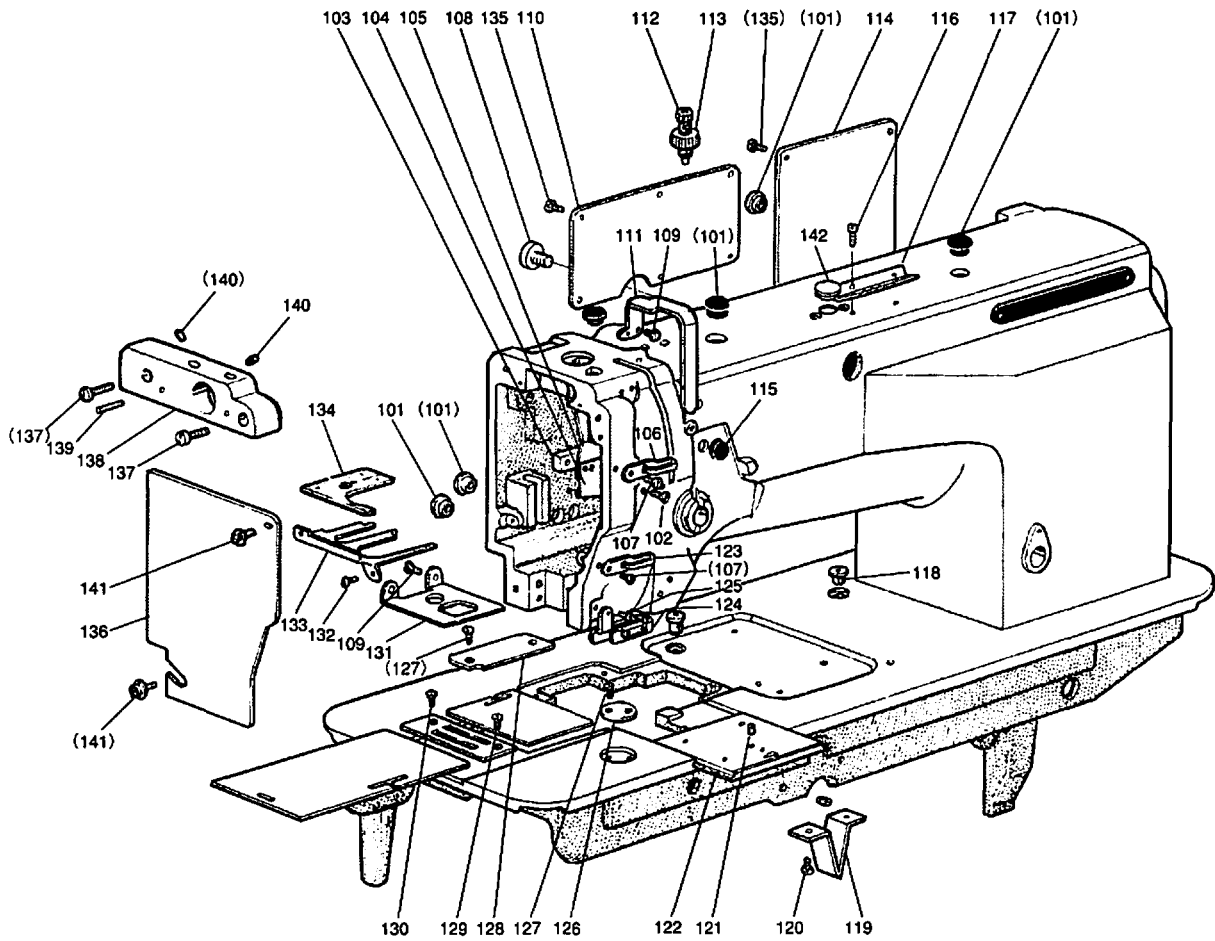

**[A] 本体部分**  
**BODY & IT'S ACCESSORIES**

Fig. No.	変更 Mod.	部品コード Parts.No.	部品名	Description	使用個数 Amt. Req.				
					LT2-2240		LT2-2250		
					NOB	BOS	M/T	A/T	BIT
A101		M91304080	セン	RUBBER PLUG 13	5	5	5	5	5
A102		M91201011	マルサラネジ	SCREW 3/16 (28) X12. 1	2	2	2	2	2
A103		MN10A0476	スペーサ	SPACER	1	1	1	1	1
A104		MN80A1131	アブラウケ	PLATE	1	1	1	1	1
A105		MN10A0131	アブラウケ	PLATE	1	1	1	1	1
A106		MN70A0181	イトアンナイ	THREAD GUIDE	1	1	1	1	1
A107		M90904011	マルサラネジ	SCREW 9/64 (40) X6. 5	2	2	2	2	2
A108		M91502004	ブライマイネジ	SCREW M6X8	1	1	1	1	1
A109		M91106004	ブライマイネジ	SCREW 11/64 (40) X8	4	4	4	4	4
A110		MN70A0880	ヨコブタ	SIDE COVER	1	1	1	1	1
A111		MN80A0584	テンビンカハ	TREAD TAKE-UP COVER	1	1	1	1	1
A112		M97003035	ツマミネジ	SCREW M10X33	1	1	1	1	1
A113		M92512045	トクシユナツト	SPECIAL NUT M10	1	1	1	1	1
A114		MN70A0237	ウラブタ	REAR COVER	1	1	1	1	1
A115		M91305080	セン	RUBBER RLUIG 13	1	1	1	1	1
A116		M91116002	ヒラネジ	SCREW 11/64 (40) X8	2	2	2	2	2
A117		MN40A0180	イトアンナイ	THREAD GUIDE	1	1	1	1	1
A118		MN10A4742	フタ	OIL CAP	2	2	2	2	2
A119		MN50A0426	ササエ	NEEDLE BAR SUPPORTER			1	1	1
A120		M91601003	マルヒラネジ	SCREW 1/4 (24) X9			2	2	2
A121		M91301001	トメネジ	SET SCREW 13/64 (32) X4	1	1	1	1	1
A122		MN70A1472	スベリイタマエクミタテ	SLIDE PLATE (FRONT)	1	1	1	1	1
A123		MN70A1181	イトアンナイ	THREAD GUIDE	1	1	1	1	1
A124		MN70E0181	イトアンナイクミタテ	THREAD GUIDE (COMPLETE)	1	1	1	1	1
A125		M90920002	ヒラネジ	SCREW 9/64 (40) X6. 5	1	1	1	1	1
A126		MN50A5742	フタ	COVER			1	1	1
A127		M90903010	サラネジ	SCREW 9/64 (40) X5			4	4	4
A128		MN72A0742	フタ	COVER			1	1	1
A129		M91106011	マルサラネジ	SCREW 11/64 (40) X8	1	1	1	1	1
A130		M90952003	マルヒラネジ	SCREW 9/64 (36) X6. 5	1	1	1	1	1
A131		MN80A0339	カハ	COVER	1	1	1	1	1
A132		M90910003	マルヒラネジ	SCREW 9/64 (40) X7	2	2	2	2	2
A133		MN80A0131	アブラウケイタ	OIL GUARD PLATE	1	1	1	1	1
A134		MN80A0740	フェルト	FELT	1	1	1	1	1
A135		M91109004	ザガネツキブライマイネジ	SCREW-PW 11/64 (40) X9	12	12	8	8	8
A136		MN80A0830	メンイタ	FACE PLATE	1	1	1	1	1
A137		M91113002	ヒラネジ	SCREW 11/64 (40) X15	2	2	2	2	2
A138		MN80A0455	ジクササエ	SHAFT SUPPORTER	1	1	1	1	1
A139		M90208061	ピン	PIN	2	2	2	2	2
A140		M91108001	トメネジ	SCREW 11/64 (40) X5. 5	2	2	2	2	2
A141		M91118004	ザガネツキブライマイネジ	SCREW-PW 11/64 (40) X7	2	2	2	2	2
A142		MP60A0500	セン	RUBBER PLUG 23	1	1	1	1	1

㊦ 上糸調節器部分(国内用)(I)

THREAD TENSION REGULATOR MECHANISM (Domestic only) (I)

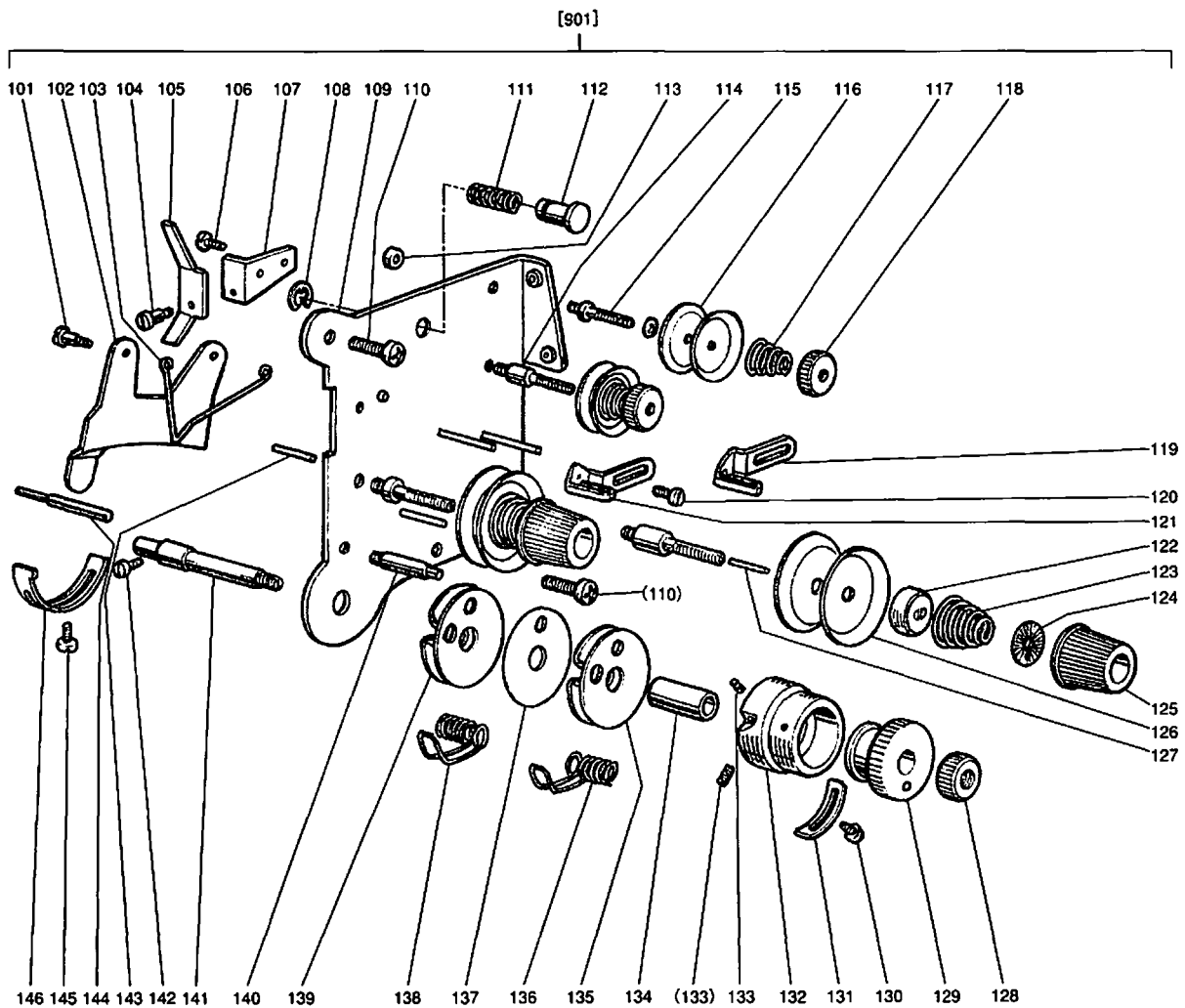

[B] 上糸調節器部分(国内用)(I)  
 THREAD TENSION REGULATOR MECHANISM(Domestic only)(I)

Fig. No.	変更 Mod.	部品コード Parts. No.	部品名	Description	使用個数 Amt. Req.				
					LT2-2240		LT2-2250		
					MOB	BOB	MTY	AIT	BIT
B101		M90902015	ヒラネジ	HINGED SCREW 9/64(40)X3	2	2	2	2	2
B102		MN50E0220	イトユルメ	TENSION RELEASING PLATE	1	1	1	1	1
B103		MN10A0851	センサイバネ	REVERSE SPRING	1	1	1	1	1
B104		M90927015	ヒラネジ	HINGED SCREW 9/64(40)X4.2			1	1	1
B105		MN72A0950	レバ	LEVER			1	1	1
B106		M90906002	ヒラネジ	SCREW 9/64(40)X4.5			1	1	1
B107		MN50A6601	トリツケイタ	MOUNTING PLATE			1	1	1
B108		M90505065	エカトトメワ 5	RETAINING RING (E TYPE) 5	1	1	1	1	1
B109		MN70E2601	トリツケイタクミタテ	MOUNTING PLATE COMPLETE	1	1	1	1	1
B110		M91106004	フ ラマイネジ	SCREW 11/64(40)X8	2	2	2	2	2
B111		MN50A4572	ツルマキバネ	COIL SPRING			1	1	1
B112		MP41A1270	押しボタ	PUSH BUTTON			1	1	1
B113		M91101045	ナット	NUT 11/64 (40)	2	2	2	2	2
B114		MN70A1553	チヨウソクウ	THREAD TENSION STUD	1	1	1	1	1
B115		MN70A0553	チヨウソクウ	THREAD TENSION STUD	1	1	1	1	1
B116		MF10A1555	チヨウソクウ	THREAD TENSION DISC	4	4	4	4	4
B117		MN70A0245	エンスイバネ	SPRING	2	2	2	2	2
B118		M91101046	ツマミナット	THUMB NUT 11/64 (40)	2	2	2	2	2
B119		MN69A0181	イトアソナイ	THREAD GUIDE		1		1	1
B120		M90909003	マルヒラネジ	SCREW 9/64(40)X6	1	1	1	1	1
B121		MN70A2181	イトアソナイ	THREAD GUIDE	1		1		
B122		MN11A0556	チヨウソクウ	THREAD TENSION RELEASING DISC	2	2	2	2	2
B123		MN10A3245	エンスイバネ	THREAD TENSION SPRING	2		2		
		MF11D0245	エンスイバネ	THREAD TENSION SPRING				2	
		MN52A1245	エンスイバネ	THREAD TENSION SPRING		2			2
B124		MT60A0802	マワリトメ	THUMB NUT REVOLUTION STOPPER	2	2	2	2	2
B125		M91610046	ツマミネジ	THUMB NUT 1/4(40)	2	2	2	2	2
B126		MF10A0555	チヨウソクウ	THREAD TENSION DISC	4	4	4	4	4
B127		M97008060	ピン	PIN	1	1	1	1	1
B128		M91611046	ツマミナット	THUMB NUT 1/4(40)	1	1	1	1	1
B129		MN70A0573	ツマミ	TAKE-UP SPRING GUIDE	1	1	1	1	1
B130		M90915003	マルヒラネジ	SCREW 9/64(40)X6	1	1	1	1	1
B131		MN70A0477	ストップ	STOPPER	1	1	1	1	1
B132		MN70A0154	アソナイ	THREAD TENSION POST	1	1	1	1	1
B133		M90802001	トメネジ	SET SCREW 1/8(44)X3.5	2	2	2	2	2
B134		MN70A0750	ブッシュ	BUSHING	1	1	1	1	1
B135		MN70E1175	イタクミタテ	PLATE COMPLETE	1	1	1	1	1
B136		MN70A1187	イトトリバネ	THREAD TAKE-UP SPRING	1	1	1	1	1
B137		MN70A0308	イタ	PLATE	1	1	1	1	1
B138		MN70A0187	イトトリバネ	THREAD TAKE-UP SPRING	1	1	1	1	1
B139		MN70E0175	イタクミタテ	PLATE COMPLETE	1	1	1	1	1
B140		M90928015	タツキネジ	SCREW 9/64(40)X2.9	1	1	1	1	1
B141		MN70A0554	チヨウソクウ	THREAD TENSION STUD	1	1	1	1	1
B142		M90910003	マルヒラネジ	SCREW 9/64(40)X7	1	1	1	1	1
B143		M97009060	ピン	PIN	1	1	1	1	1
B144		M90516060	イトユルメ	THREAD RELEASING PIN			1	1	1
		M90521060	イトユルメ	TENSION RELEASING PIN	1	1			
B145		M90920002	ヒラネジ	SCREW 9/64(40)X6.5	1	1	1	1	1
B146		MN10A0477	ストップ	STOPPER	1	1	1	1	1
B901		MN70E0210	チヨウセツキミタテ	THREAD TENSION REGULATOR COMPLETE	1				
		MN69E0210	チヨウセツキミタテ	THREAD TENSION REGULATOR COMPLETE		1			
		MN72E0210	チヨウセツキミタテ	THREAD TENSION REGULATOR COMPLETE			1		
		MN84E0210	チヨウセツキミタテ	THREAD TENSION REGULATOR COMPLETE				1	
		MN74E0210	チヨウセツキミタテ	THREAD TENSION REGULATOR COMPLETE					1

☐ 上糸調節器部分(輸出用)(Ⅱ)  
 THREAD TENSION REGULATOR MECHANISM (Export only) (Ⅱ)

LT2-2250

[902]

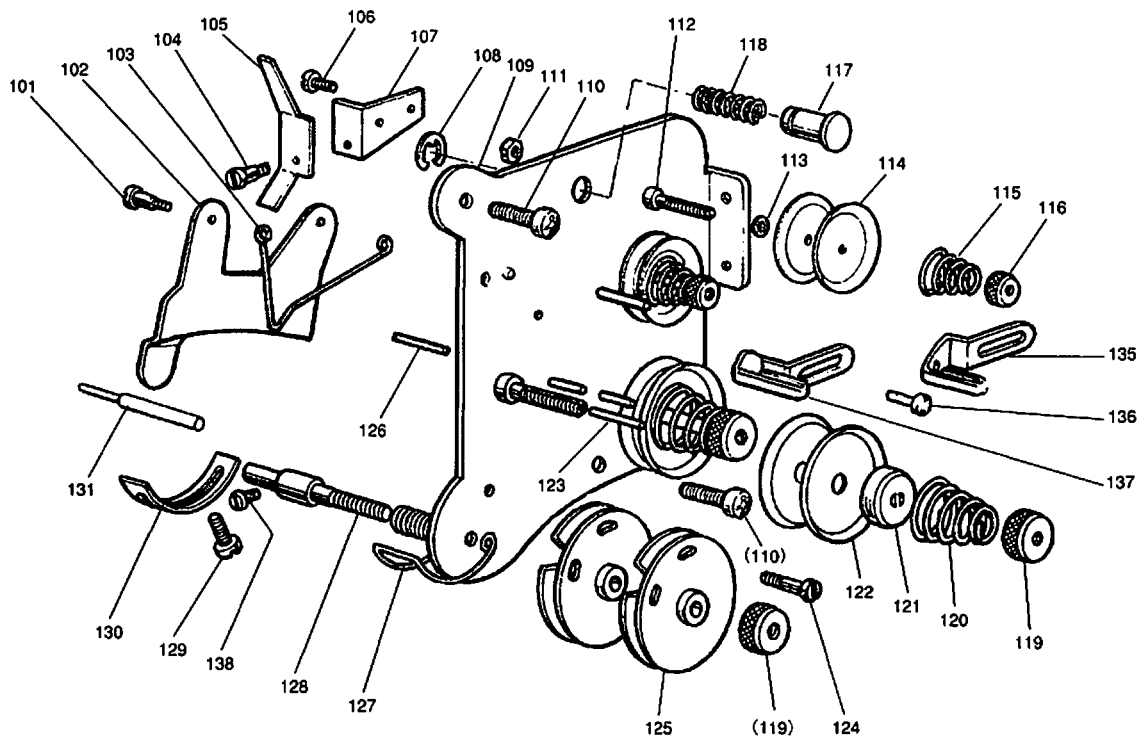

LT2-2240

[901]

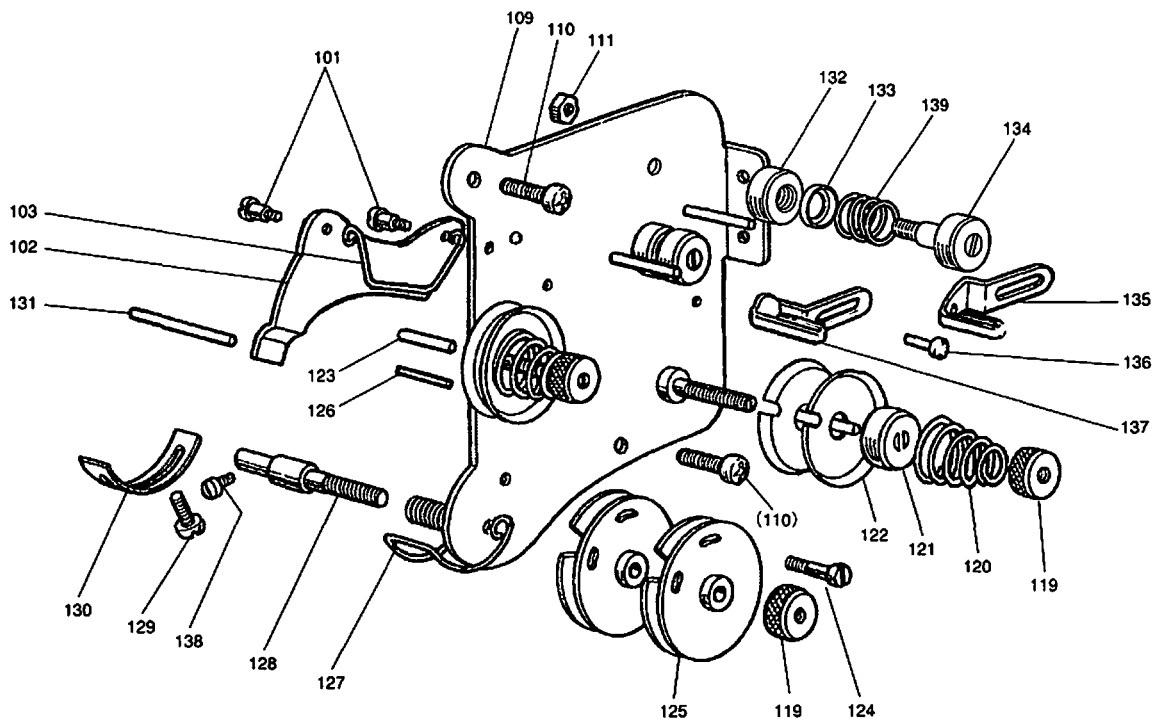

**[C] 上系調節器部分(輸出用)(Ⅱ)**  
**THREAD TENSION REGULATOR MECHANISM(Export only)(Ⅱ)**

Fig. No.	変更 Mod.	部品コード Parts. No.	部品名	Description	使用個数 Amt. Req.				
					LT2-2240	LT2-2250			
					MOB	BOB	MTW	AIT	BIT
C101		M90902015	ヒラネジ ﾀﾞﾝｼﾞｷ	HINGED SCREW 9/64(40)X3	2	2	2	2	2
C102		MN10A0220	イトユルメ	TENSION RELEASING PLATE	1	1			
		MN50E0220	イトユルメ	TENSION RELEASING PLATE			1	1	1
C103		MN10A0851	センサイクハ ｽﾍﾞ	REVERSE SPRING	1	1	1	1	1
C104		M90927015	ヒラネジ ﾀﾞﾝｼﾞｷ	HINGED SCREW 9/64(40)X4.2			1	1	1
C105		MN72A0950	ﾚﾊﾞ	LEVER			1	1	1
C106		M90906002	ヒラネジ	SCREW 9/64(40)X4.5			1	1	1
C107		MN50A6601	ﾄﾘｯｼﾞｲﾀ	MOUNTING PLATE			1	1	1
C108		M90505065	ｴｶﾞﾀ ﾄﾓｸﾞ 5	RETAINING RING (E TYPE) 5			1	1	1
C109		MN70E0601	ﾄﾘｯｼﾞｲﾀｸﾐﾀﾃ	MOUNTING PLATE COMPLETE	1	1			
		MN72E0601	ﾄﾘｯｼﾞｲﾀｸﾐﾀﾃ	MOUNTING PLATE COMPLETE			1	1	1
C110		M91106004	ﾌﾞﾗｲﾅｼﾞ	SCREW 11/64(40)X8	2	2	2	2	2
C111		M90901045	ﾅｯﾄ	NUT 9/64 (40)	2	2			
		M91101045	ﾅｯﾄ	NUT 11/64 (40)			1	1	1
C112		MF10A1553	ﾁｮｳｼﾞｷ	THREAD TENSION STUD			2	2	2
C113		M90401050	ｼﾞﾞｶﾞ ｽﾍﾞ	WASHER 4			1	1	1
C114		MN50A0555	ﾁｮｳｼﾞｷ	THREAD TENSION DISC			4	4	4
C115		MP61A0245	ｺｲﾙ ｽﾍﾞ	SPRING			2	2	2
C116		M91609046	ツﾏﾐﾅｯﾄ	THUMB NUT 1/4 (40)			2	2	2
C117		MP41A1270	ｵｼﾞｷ ﾀﾝ	PUSH BUTTON			1	1	1
C118		MN50A4572	ツﾙﾏｷﾊﾞ ｽﾍﾞ	COIL SPRING			1	1	1
C119		M91603046	ツﾏﾐﾅｯﾄ	THUMB NUT 1/4 (40)	3	3	3	3	3
C120		MN10A3245	ｴﾝｽｲﾊﾞ ｽﾍﾞ	THREAD TENSION SPRING	2		2		
		MF10A0245	ｴﾝｽｲﾊﾞ ｽﾍﾞ	THREAD TENSION SPRING		2			
		MF11D0245	ｴﾝｽｲﾊﾞ ｽﾍﾞ	THREAD TENSION SPRING				2	
		MN52A1245	ｴﾝｽｲﾊﾞ ｽﾍﾞ	THREAD TENSION SPRING					2
C121		MN10A0556	ﾁｮｳｼﾞｷ ｻﾞｵｻﾞ	THREAD TENSION RELEASING DISC	2	2	2	2	2
C122		MN10A0555	ﾁｮｳｼﾞｷ	THREAD TENSION DISC	4	4	4	4	4
C123		M90202060	ﾋﾞﾝ	THREAD RELEASING PIN 2X12	1	1	1	1	1
C124		M90603003	ﾏﾙﾋﾗﾅｼﾞ	SCREW 3/32(56)X12	1	1	1	1	1
C125		MN10E0175	ｲﾀｸﾐﾀﾃ	THREAD CONTROL DISC ASSY	2	2	2	2	2
C126		M90203060	ﾋﾞﾝ	PIN	1	1	1	1	1
C127		MN10A0187	ｲﾄﾄﾘﾊﾞ ｽﾍﾞ	THREAD TAKE-UP SPRING	1	1	1	1	1
C128		MN10A0554	ﾁｮｳｼﾞｷ	THREAD TENSION STUD	1	1	1	1	1
C129		M90920002	ヒラネジ	SCREW 9/64(40)X6.5	1	1	1	1	1
C130		MN10A0477	ｽﾄｯﾊﾟ	STOPPER	1	1	1	1	1
C131		M90521060	イトユルメ ｻﾞ	TENSION RELEASING PIN	1	1			
		M90516060	イトユルメ ｻﾞ	THREAD RELEASING PIN			1	1	1
C132		MN10A0155	ｱﾝﾅｲﾀﾞ ｲ	THREAD GUIDE BRACKET	2	2			
C133		MN10A1555	ﾁｮｳｼﾞｷ	THREAD TENSION DISC	2	2			
C134		M90930016	ﾏﾙﾋﾗﾅｼﾞ ﾀﾞﾝｼﾞｷ	SCREW	2	2			
C135		MN69A0181	ｲﾄｱﾝﾅｲ	THREAD GUIDE			1	1	1
C136		M90909003	ﾏﾙﾋﾗﾅｼﾞ	SCREW 9/64(40)X6	1	1	1	1	1
C137		MN70A2181	ｲﾄｱﾝﾅｲ	THREAD GUIDE	1		1		
C138		M90910003	ﾏﾙﾋﾗﾅｼﾞ	SCREW 9/64(40)X7	1	1	1	1	1
C139		MN10A1572	ツﾙﾏｷﾊﾞ ｽﾍﾞ	COIL SPRING	2	2			
C901		MN70E1210	ﾁｮｳｼﾞｷ	THREAD TENSION REGULATOR COMPLETE	1				
		MN69E1210	ﾁｮｳｼﾞｷ	THREAD TENSION REGULATOR COMPLETE		1			
C902		MN72E1210	ﾁｮｳｼﾞｷ	THREAD TENSION REGULATOR COMPLETE			1		
		MN83E0210	ﾁｮｳｼﾞｷ	THREAD TENSION REGULATOR COMPLETE				1	
		MN74E1210	ﾁｮｳｼﾞｷ	THREAD TENSION REGULATOR COMPLETE					1



㊦ 上軸・押え・ひざ上げ機構  
 UPPER SHAFT & PRESSER FOOT MECHANISM

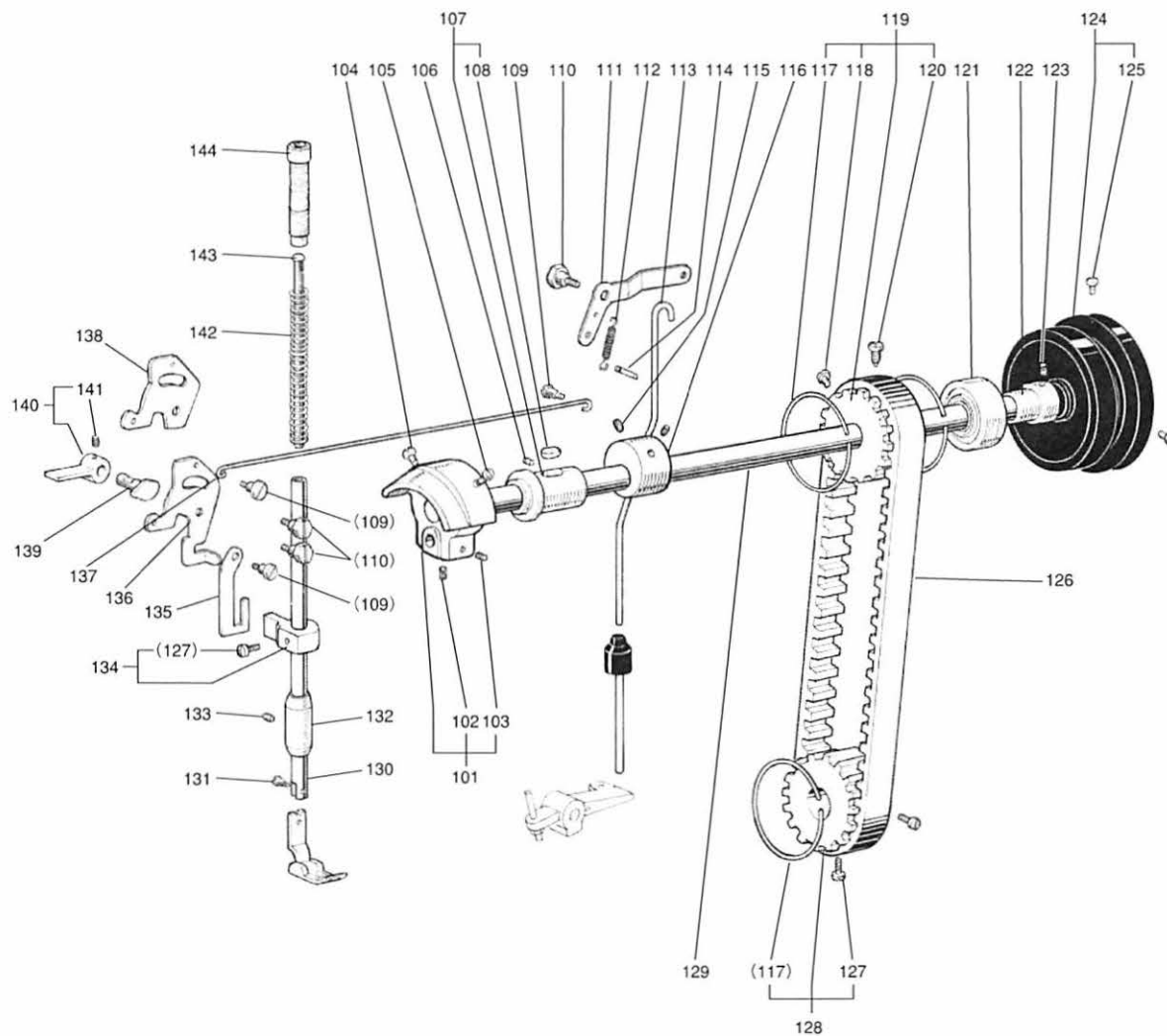

[D] 上軸・押え・ひざ上げ機構  
UPPER SHAFT & PRESSER FOOT MECHANISM

Fig. No.	変更 No.	部品コード Parts.No.	部品名	Description	使用個数 Amt. Req.				
					LT2-2240		LT2-2250		
					NOB	BOB	MTW	AIT	BIT
D101		MN80E0383	クランクミタテ	CRANK	1	1	1	1	1
D102		M91602001	トメネジ	SET SCREW 1/4 (40) X4	1	1	1	1	1
D103		M91606001	トメネジ	SET SCREW 1/4 (40) X6	1	1	1	1	1
D104		M91801002	ヒラネジ	SCREW 9/32 (28) X13	1	1	1	1	1
D105		M91802006	ヒラネジ 糸 寸サキ	SCREW 9/32 (28) X14	1	1	1	1	1
D106		M91516001	トメネジ	SET SCREW 15/64 (28) X13	1	1	1	1	1
D107		MN70A0232	ウツジクメタルヒタリクミタテ	ARM SHAFT BUSHING LEFT (COMPLETE)	1	1	1	1	1
D108		MN10A6740	フェルト	FELT	1	1	1	1	1
D109		M91219015	ヒラネジ ダンツキ	HINGED SCREW 3/16 (28) X3.5	3	3	3	3	3
D110		M91503031	糸 ルト	SPECIAL BOLT 15/64 (28) X6.7	3	3	3	3	3
D111		MN70A0252	オサエアケレバニミキ	KNEE LIFTER LEVER (RIGHT)	1	1	1	1	1
D112		MN70A0572	ツルマキハネ	SPRING	1	1	1	1	1
D113		MN70A0511	ソウサキウ	KNEE LIFTER CONNECTING ROD	1	1	1	1	1
D114		M95004067	ミゾツキヒン BXカク 5X28	PIN	1	1	1	1	1
D115		M91513001	トメネジ	SET SCREW 15/64 (28) X10	2	2	2	2	2
D116		MN81A0721	ハランズウエイト	BLANCE WEIGHT	1	1	1	1	1
D117		MN10A1851	センサイクハネ	SPRING FLANGE	3	3	3	3	3
D118		M91502002	ヒラネジ	SCREW 15/64 (28) X12	1	1	1	1	1
D119		MP41A0767	ハカクハルトクノルマクミタテ	PULLEY COMPLETE	1	1	1	1	1
D120		M91501007	マルヒラネジ 糸 寸サキ	SCREW 15/64 (28) X14.5	1	1	1	1	1
D121		MN10A1456	ジクウケ 6204ZZNR	BALL BEARING	1	1			
D122		MN40A1750	ブツシユ	BUSHING FOR ARM SHAFT	1	1			
D123		M91516002	ヒラネジ	SCREW 15/64 (28) X8.5	2	2			
D124		MN70E0682	プーリー	PULLEY	1	1			
D125		M91502002	ヒラネジ	SCREW 15/64 (28) X12	2	2			
D126		MN10A0523	ハカクハルト	COG BELT	1	1	1	1	1
D127		M91515002	ヒラネジ	SCREW 15/64 (28) X10	3	3	3	3	3
D128		MN70A0768	ハカクハルトクノルマクミタテ	PULLEY COMPLETE (LOWER)	1	1			
		MN72A0768	ハカクハルトクノルマクミタテ	PULLEY COMPLETE (LOWER)			1	1	1
D129		MN80A0230	ウツジク	ARM SHAFT	1	1			
		MN82A0230	ウツジク	ARM SHAFT			1	1	1
D130		MN70A0262	オサエホウ	PRESSER BAR	1	1	1	1	1
D131		M90851015	ヒラネジ ダンツキ	HINGED SCREW 1/8 (44) X4	1	1	1	1	1
D132		MF00A0267	オサエホウメタル	BUSHING FOR PRESSER BAR	1	1	1	1	1
D133		M91513001	トメネジ	SET SCREW 15/64 (28) X10	1	1	1	1	1
D134		MN70A0265	オサエホウウタキクミタテ	PRESSER BAR GUIDE BRACKET	1	1	1	1	1
D135		MN70A0510	ソウサイタ	OPERATION PLATE	1	1	1	1	1
D136		MN70A1252	オサエアケレバニヒタリ	KNEE LIFTER LEVER LEFT	1	1			
D137		MN70A0738	ヒキホウ	KNEE LIFTER ROD	1	1	1	1	1
D138		MN72A1252	オサエアケレバニヒタリ	KNEE LIFTER LEVER LEFT			1	1	1
D139		MN70A0253	オサエアケカム	PRESSER BAR LIFTING CAM	1	1	1	1	1
D140		MN70A2252	オサエアケクミタテ	PRESSER BAR LIFTER (COMPLETE)	1	1	1	1	1
D141		M91108001	トメネジ	SET SCREW 11/64 (40) X5.5	2	2	2	2	2
D142		MN82A0259	ツルマキハネ	PRESSER SPRING	1	1	1	1	1
D143		MF20A0703	アンナイホウ	PRESSER SPRING GUIDE	1	1	1	1	1
D144		M93220035	ツマミネジ	THUMB NUT 1/2 (28) X49	1	1	1	1	1

☒ 天秤・針棒揺動機構

THREAD TAKE-UP LEVER & NEEDLE BAR ROCK MOTION MECHANISM

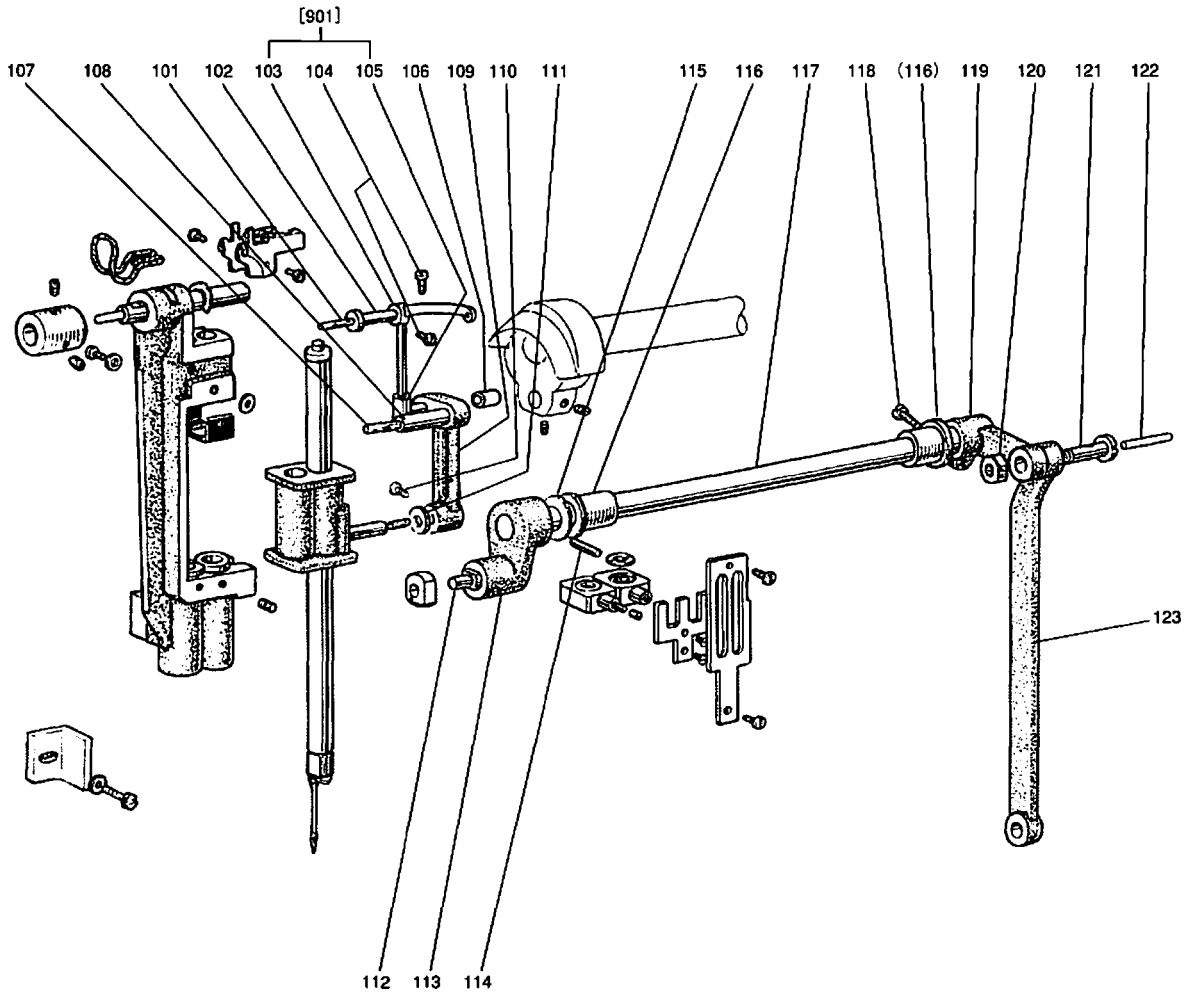

[E] 天秤・針棒揺動機構  
 THREAD TAKE-UP LEVER & NEEDLE BAR ROCK MOTION MECHANISM

Fig. No.	変更 No.	部品コード Parts. No.	部品名	Description	使用個数 Amt. Req.				
					LT2-2240		LT2-2250		
					NOB	BOB	M/TW	A/T	B/T
E101		MF10E2148	ヒモ	OIL WICK	1	1	1	1	1
E102		MN70A0587	テンビ <sup>ン</sup> サエジ <sup>ク</sup>	THREAD TAKE-UP GUIDE BRACKET PIN	1	1	1	1	1
E103			テンビ <sup>ン</sup>	THREAD TAKE-UP LEVER	1		1		
			テンビ <sup>ン</sup>	THREAD TAKE-UP LEVER		1		1	1
E104		M91502002	ヒラネジ	SCREW 15/64 (28) X12	3	3	3	3	3
E105		MN10A0588	スベ <sup>リ</sup> カ <sup>ネ</sup>	SLIDE BLOCK FOR TAKE-UP LEVER	1	1	1	1	1
E106		MN10A0500	セン	PLUG	1	1	1	1	1
E107		MP60A0148	ヒモ	OIL WICK 3X80	1	1	1	1	1
E108		MN70A0387	ハリ <sup>ネ</sup> ウヨウ <sup>ト</sup> ウテ <sup>ミ</sup> カ <sup>リ</sup>	NEEDLE BAR CRANK PIN	1	1	1	1	1
E109		MN55A1956	レンセツカン	NEEDLE BAR CONNECTING LINK	1	1	1	1	1
E110		M90939002	ヒラネジ	SCREW 9/64 (40) X11	1	1	1	1	1
E111		MN55A0750	ブ <sup>ツ</sup> シユ	BUSHING	1	1	1	1	1
E112		M90509060	サエジ <sup>ク</sup>	CONNECTING STUD	1	1	1	1	1
E113		MP60A0672	ハリ <sup>ネ</sup> ウヨウ <sup>ト</sup> ウテ <sup>ミ</sup> カ <sup>リ</sup>	NEEDLE BAR ROCKING SHAFT CRANK	1	1	1	1	1
E114		M90401061	テ <sup>ハ</sup> ビ <sup>ン</sup>	PIN $\Phi$ 4x23x1/50	1	1	1	1	1
E115		M91503050	サ <sup>カ</sup> ネ	WASHER 15	1	1	1	1	1
E116		MN40A0669	ハリ <sup>ネ</sup> ウヨウ <sup>ト</sup> ウシ <sup>ク</sup> メタル	BUSHING FOR NEEDLE BAR ROCK SHAFT	2	2	2	2	2
E117		MN80A0668	ハリ <sup>ネ</sup> ウヨウ <sup>ト</sup> ウシ <sup>ク</sup>	NEEDLE BAR ROCK SHAFT	1	1	1	1	1
E118		M91603003	マルヒラネジ	SCREW 1/4 (24) X16	1	1	1	1	1
E119		MN55A2672	ハリ <sup>ネ</sup> ウヨウ <sup>ト</sup> ウテ <sup>ミ</sup> キ	CONNCTING CRANK	1	1	1	1	1
E120		M92002045	ナツト	NUT 5/16 (24)	1	1	1	1	1
E121		M92001015	ヒラネジ タ <sup>ン</sup> ツキ	HINGED SCREW 5/16 (24) X6	1	1	1	1	1
E122		MF10E2148	ヒモ	OIL WICK	1	1	1	1	1
E123		MN25A0671	レンセツカン	LINK	1	1	1	1	1
E901		MN80E0582	テンビ <sup>ン</sup> スベ <sup>リ</sup> カ <sup>ネ</sup> ネクミタテ	THREAD TAKE-UP LEVER & LINK (COMPLETE)	1		1		
		MN81E0582	テンビ <sup>ン</sup> スベ <sup>リ</sup> カ <sup>ネ</sup> ネクミタテ	THREAD TAKE-UP LEVER & LINK (COMPLETE)		1		1	1



[F] 針棒機構  
NEEDLE BAR MECHANISM

Fig. No.	変更 Mod.	部品コード Parts. No.	部品名	Description	使用個数 Amt. Req.				
					LT2-2240		LT2-2250		
					MOB	BOS	MTY	AIT	BIT
F101		MN80A0750	ブッシュ	BUSHING	1	1	1	1	1
F102		M91503001	トメネジ	SCREW 15/64 (28) X4.5	2	2	2	2	2
F103		M90915003	マルヒラネジ	SCREW 9/64 (40) X6	3	3	3	3	3
F104		MN25A0192	イタハネ	SPRING	1	1	1	1	1
F105		MF10E3148	ヒモ	OIL WICK Φ3x210	1	1	1	1	1
F106		MN55A0148	ヒモ	OIL WICK Φ3x55	1	1	1	1	1
F107		MN80A0666	ササエ	NEEDLE BAR SUPPORTER	1	1	1	1	1
F108		M90309064	スプリングピン	SPRING PIN 3X22	1	1	1	1	1
F109		M90507065	エカクシメ	RETAINING RING (E TYPE) 7	1	1	1	1	1
F110		MN80A0454	ジク	NEEDLE BAR SUPPORTER GUIDE PIN	1	1	1	1	1
F111		MN80A0780	ホルダ	HOLDER	1	1	1	1	1
F112		MN80A1780	ホルダ	HOLDER	1	1	1	1	1
F113		MN25A1477	ストップ	STOPPER	1	1	1	1	1
F114		M93002050	ワッシャ	WASHER	1	1	1	1	1
F115		M90974002	ヒラネジ	SCREW 9/64 (40) X6.5	1	1	1	1	1
F116		MN80A0154	アンナイタ	GUIDE PLATE	1	1	1	1	1
F117		M90944003	マルヒラネジ	SCREW 9/64 (40) X5	1	1	1	1	1
F118		M90613011	マルサネジ	SCREW 3/32 (56) X4.2	2	2	2	2	2
F119		MN25A0426	ササエ	NEEDLE BAR SUPPORTER	1	1	1	1	1
F120		MN25A1665	ハリホウキ	NEEDLE BAR HOLDER (RIGHT)	1	1	1	1	1
F121		M90901020	ロツカクアツキトメネジ	SET SCREW 9/64 (40) X3.5	2	2	2	2	2
F122		MN25A0161	アテガネ	NEEDLE BAR HOLDING STOPPER	2	2	2	2	2
F123		MN25A2665	ハリホウキ	NEEDLE BAR HOLDER (LEFT)	1	1	1	1	1
F124		MN25A0476	スペーサ	SPACER	4	4	4	4	4
F125		MN80A0665	ハリホウキ	NEEDLE BAR HOLDER	1	1	1	1	1
F126		MN25A0833	ハリホウキ	BUSHING FOR NEEDLE BAR SUPPORTER	2	2	2	2	2
F127		M90107024	ミソツキネジ	BOLT 11/64 (40) X12	1	1	1	1	1
F128		M90450050	ワッシャ	WASHER	1	1	1	1	1
F129		MN80A1154	アンナイガネ	NEEDLE BAR GUIDE	1	1	1	1	1
F130		MV01A0128	ミシンハリ	NEEDLE (DPX5-14)	2		2	2	
		MN10A1128	ミシンハリ	NEEDLE (DPX5-18)		2			2
F131		M90802001	トメネジ	SET SCREW 1/8 (44) X3.9	2	2	2	2	2
F132		M90806001	トメネジ	SET SCREW 1/8 (44) X6	4	4	4	4	4
F133		MN80A0477	ストップ	STOPPER FOR NEEDLE CLAMP	2	2	2	2	2
F134		MN25A2572	ツルマキバネ	SPRING	2	2	2	2	2
F135		MN80A0660	ハリホウキ	NEEDLE BAR	2	2	2	2	2
F136		M95002063	サンカクピン	TRIANGLE PIN	2	2	2	2	2
F137		M98001070	コウキユウ	STEEL BALL 3/32	12	12	12	12	12
F138		MN25A0411	コロ	STUD	2	2	2	2	2
F139		MN80A0572	ツルマキバネ	SPRING	2	2	2	2	2
F140		M90501045	ナット	NUT 5/64 (64)	2	2	2	2	2
F141		M90502047	トクシユナット	NUT 5/64 (64) X9.5	2	2	2	2	2
F142		M95003063	トクシユピン	PIN	2	2	2	2	2
F143		MN25A0482	スリーブ	SLEEVE	2	2	2	2	2
F144		MN25A1572	ツルマキバネ	SPRING	2	2	2	2	2
F145		M90214063	タングキピン	PIN	2	2	2	2	2
F146		M94004030	トクシユネジ	SCREW M5.5X5	2	2	2	2	2
F147		MN10A0740	フェルト	FELT	1	1	1	1	1
F148		MN85A0325	カクコ	SQUARE BLOCK	1	1	1	1	1
F149		M90901001	トメネジ	SET SCREW 9/64 (40) X3.5	2	2	2	2	2
F908		MN80E0666	ハリホウキ	NEEDLE BAR SUPPORTER ASSY.	1	1	1	1	1

G 針棒切换機構  
 NEEDLE BAR CONTROL MECHANISM

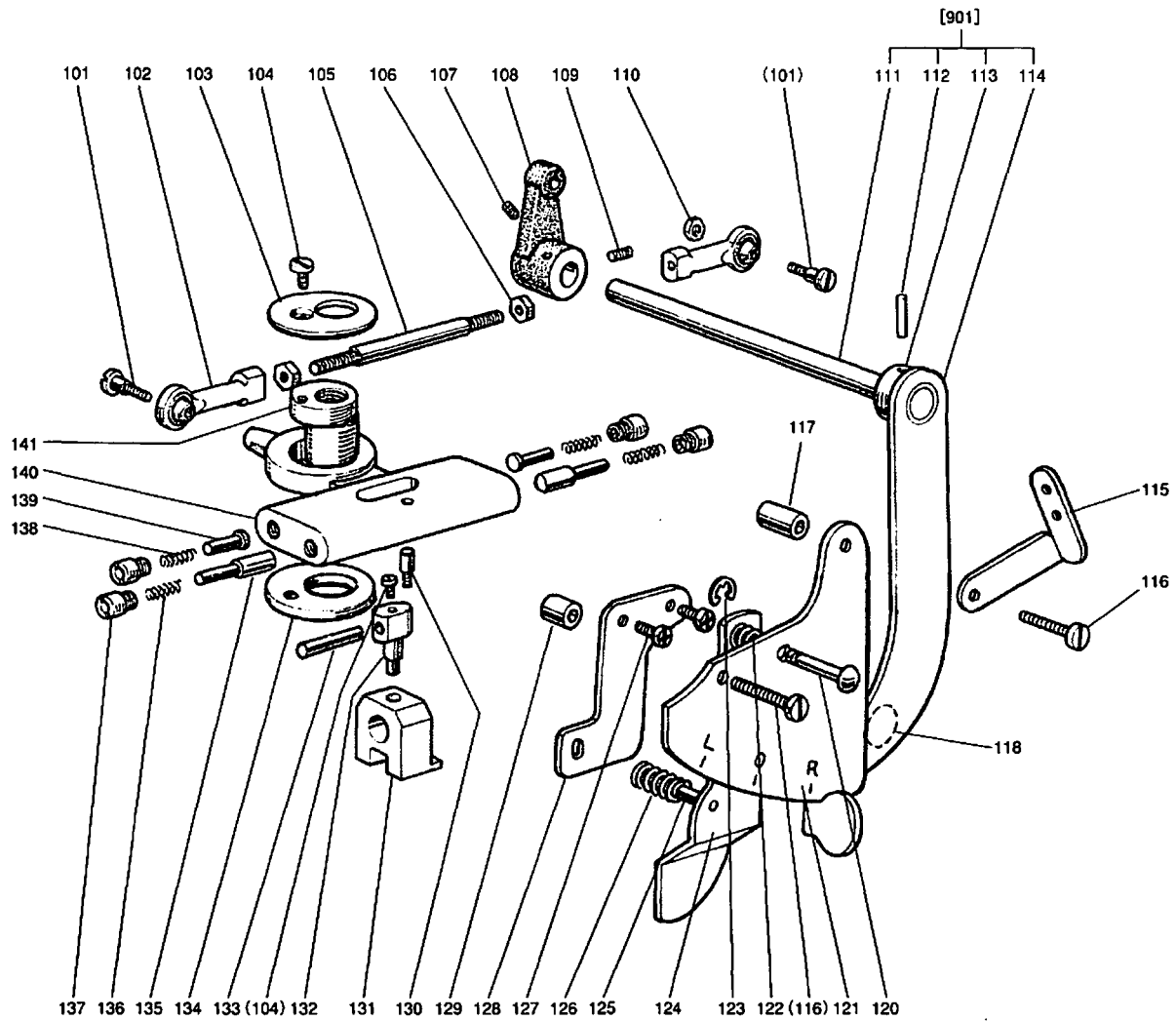

**[G] 針棒切換機構**  
**NEEDLE BAR CONTROL MECHANISM**

Fig. No.	変更 No.	部品コード Parts No.	部品名	Description	使用個数 Amt. Req.				
					LT2-2240		LT2-2250		
					MOB	BOB	MTY	AIT	BIT
G101		M91101015	ヒラネジ	SCREW 11/64 (40) X9.5	2	2	2	2	2
G102		MB62A0975	ロツエント	BALL JOINT	2	2	2	2	2
G103		MN80A0742	フタ	COVER	1	1	1	1	1
G104		M90903002	ヒラネジ	SCREW 9/64 (40) X6.5	2	2	2	2	2
G105		M95005023	ウエコミネ	CONNECTING ROD	1	1	1	1	1
G106		M91372045	ナツト	NUT 5	2	2	2	2	2
G107		M91108001	トメネジ	SCREW 11/64 (40) X5.5	1	1	1	1	1
G108		MN80A0228	ウテ	ARM	1	1	1	1	1
G109		M92003020	ロツカクアツキトメネジ	BOLT 15/64 (28) X8	1	1	1	1	1
G110		M91103045	ナツト	NUT 11/64 (40)	1	1	1	1	1
G111		MN80A1454	ジク	SHAFT	1	1	1	1	1
G112		M90402064	スプリングピン	SPRING PIN 3X18	1	1	1	1	1
G113		MN80A1750	ブツシュ	BUSHING	1	1	1	1	1
G114		MN60A0678	ハライチハンカシレバ	STOP MOTION CONTROL LEVER	1	1	1	1	1
G115		MN80A0180	ハリアンナイ	THREAD GUIDE	1	1	1	1	1
G116		M91113002	ヒラネジ	SCREW 11/64 (40) X15	2	2	2	2	2
G117		MN80A1688	パイプ	PIPE	1	1	1	1	1
G118		M99083063	タツキピン	PIN	1	1	1	1	1
G120		M90518063	タツキピン	PIN	1	1	1	1	1
G121		MN80A0601	トリツケイタ	LEVER POSITION PLARE	1	1	1	1	1
G122		MN25A4572	ツルマキハネ	SPRING	1	1	1	1	1
G123		M90504065	エガタトメワ	E-TYPE STOP RING 4	1	1	1	1	1
G124		MN55A0950	レバ	LEVER	1	1	1	1	1
G125		M90404060	ピン	PIN	1	1	1	1	1
G126		MN60A3572	ツルマキハネ	SPRING	1	1	1	1	1
G127		M91106004	フライネジ	SCREW 11/64 (40) X8	2	2	2	2	2
G128		MN25A0601	トリツケイタ	PLATE	1	1	1	1	1
G129		MN80A0688	パイプ	PIPE	1	1	1	1	1
G130		M90906033	ピンネジ	SCREW 9/64 (40) X5	1	1	1	1	1
G131		MN80A0350	キリカエカム	CAM	1	1	1	1	1
G132		MN60A0154	アンナイピン	GUIDE PIN	1	1	1	1	1
G133		M90704060	ピン	PIN	1	1	1	1	1
G134		M93004052	トクシユサガネ	WASHER	1	1	1	1	1
G135		M90319063	トクシユピン	PIN	2	2	2	2	2
G136		MN60A4572	ツルマキハネ	SPRING	2	2	2	2	2
G137		M92002030	トクシユネジ	CAM SCWER 5/16 (28) X4	4	4	4	4	4
G138		MN60A0572	ツルマキハネ	SPRING	2	2	2	2	2
G139		M90317063	ツバツキピン	PIN	2	2	2	2	2
G140		MN60A1155	アンナイガイド	GUIDE	1	1	1	1	1
G141		MN80A0267	ハリホウメタル	BUSHING	1	1	1	1	1
G901		MN80E0775	ハライチハンカシレバ	STOP MOTION CONTROL LEVER ASSY.	1	1	1	1	1



縫目加減機構  
STITCH REGULATOR MECHANISM

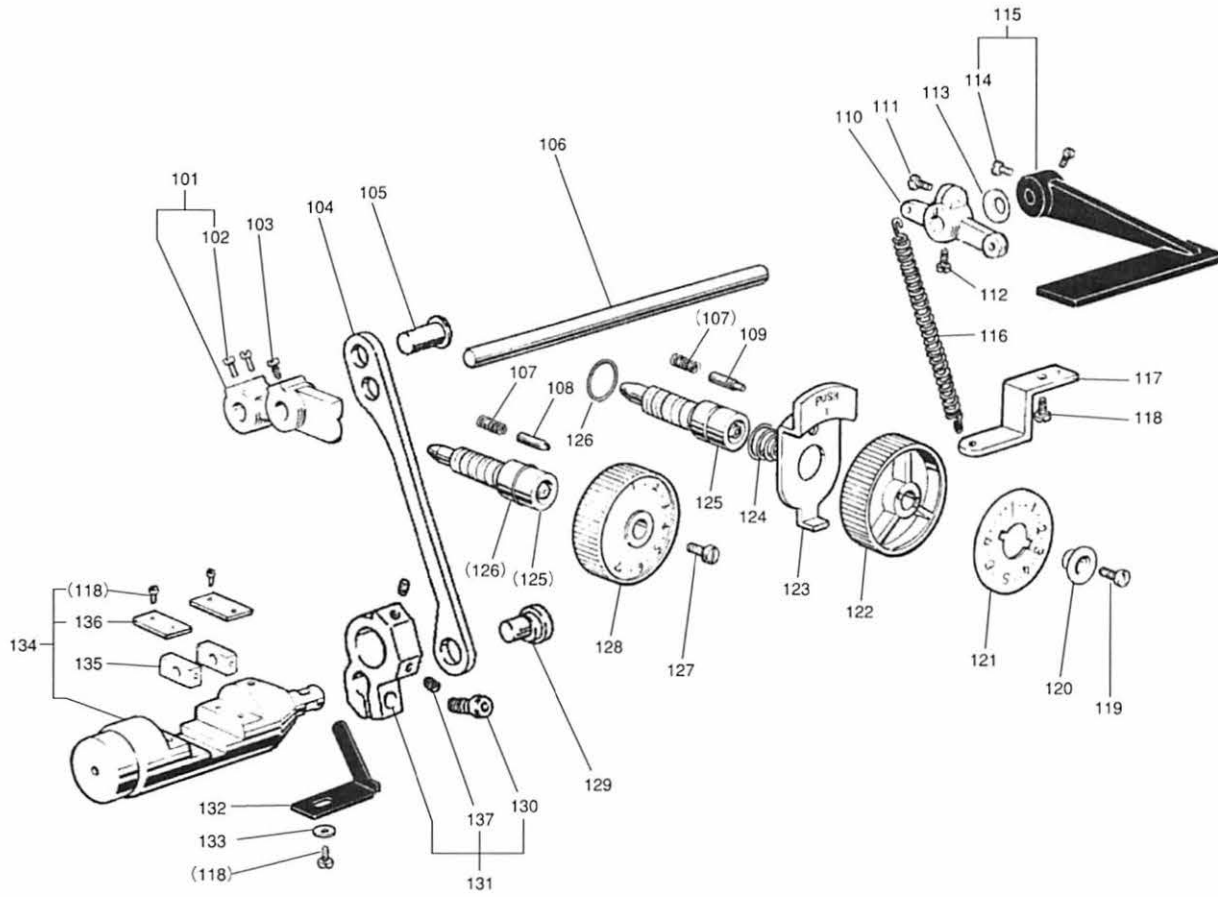

[H] 縫目加減機構  
STITCH REGULATOR MECHANISM

Fig. No.	変更 Mod.	部品コード Parts. No.	部品名	Description	使用個数 Amt. Req.				
					LT2-2240		LT2-2250		
					MOB	BOB	MTY	ATT	BIT
H101		MN70A0291	オクリヨウセツカムミタテ	FEED REGULATOR (COMPLETE)	1	1	1	1	1
H102		M91516002	ヒラネジ	SCREW 15/64 (28) X8.5	2	2	2	2	2
H103		M91505007	ヒラネジ ホウサキ	SCREW 15/64 (28) X10.5	1	1	1	1	1
H104		MN70A2956	レンセツカン	CONNECTING LINK	1	1	1	1	1
H105		M90904060	ピン	PIN	1	1	1	1	1
H106		MN70A0320	カエシスイジクウエ	REVERSE STITCH SHAFT (UPPER)	1	1			
		MN72A0320	カエシスイジクウエ	REVERSE STITCH SHAFT (UPPER)			1	1	1
H107		MF10A2572	ツルマキハネ	SCREW M6X8	1	1	1	1	1
H108		MF80A0852	ピン	STOPPER PIN FOR FEED REGULATING DIAL	1	1			
H109		MF00A0852	ピン	STOPPER PIN			1	1	1
H110		MP60A0228	ウテ	ARM	1	1			
		MN50A6228	ウテ	ARM			1	1	1
H111		M91505002	ヒラネジ	SCREW 15/64 (28) X13.5	1	1	1	1	1
H112		M91102002	ヒラネジ	SCREW 11/64 (40) X8.5	1	1	1	1	1
H113		M95003053	ハネサガネ	SPRING WASHER 10	1	1			
H114		M91516002	ヒラネジ	SCREW 15/64 (28) X8.5	2	2			
H115		MN70A0632	ヌイメカゲンレバークミタテ	REVERSE SEWING LEVER (COMPLETE)	1	1			
		MN72A0632	ヌイメカゲンレバークミタテ	REVERSE SEWING LEVER			1	1	1
H116		MN40A0572	ツルマキハネ	COIL SPRING	1	1	1	1	1
H117		MN40A0154	アンナイイタ	GUIDE PLATE	1	1			
H118		M91106004	フアラマイネジ	SCREW 11/64 (40) X8	6	6	5	5	5
H119		M91215002	ヒラネジ	SCREW 3/16 (28) X12			1	1	1
H120		MF00A0257	オサエガネ	BUSHING			1	1	1
H121		MN82A0841	メモリイタ	STITCH LENGTH INDICATING PLATE			1	1	
		MN74A0841	メモリイタ	STITCH LENGTH INDICATING PLETE					1
H122		MF01A0631	ダイヤル	DIAL			1	1	1
H123		MF00A0950	レバ	STOPPER PIN RELEASING LEVER			1	1	1
H124		MF02A0245	エンスイハネ	COIL SPRING			1	1	1
H125		MF90A0640	オクリヨウセツネジ	STITCH LENGTH ADJUSTABLE SCREW	1	1	1	1	1
H126		M91000085	Oリング 1AP10A	O-RING 1AP10	1	1	1	1	1
H127		M91209002	ヒラネジ	SCREW 3/16 (28) X8	1	1			
H128		MF85A1631	ダイヤル	DIAL	1				
		MN69A0631	ダイヤル	DIAL		1			
H129		MP60A0761	ハンシンジク	ECCENTRIC PIN	1	1	1	1	1
H130		M95014021	ロツカクアナツキネルト	SCREW M5X14	1	1	1	1	1
H131		MN70E1635	ヌイメカゲンウテシタクミタテ	NEEDLE PLATE	1	1	1	1	1
H132		MN70A0257	カエシイサエイタ	HOLDING PLATE OF REVERSE BAR	1	1	1	1	1
H133		M93002050	サガネ	WASHER	1	1	1	1	1
H134		MN70A0321	カエシイサエイタ	REVERSE BAR (COMPLETE)	1	1	1	1	1
H135		MN70A0325	カクコマ	SQUARE BLOCK	2	2	2	2	2
H136		MN70A1154	アンナイイタ	GUIDE PLETE	2	2	2	2	2
H137		M95008020	コネジ	SCREW M5X6	2	2	2	2	2

下軸・送り機構

LOWER SHAFT & FEED ROCK SHAFT MECHANISM

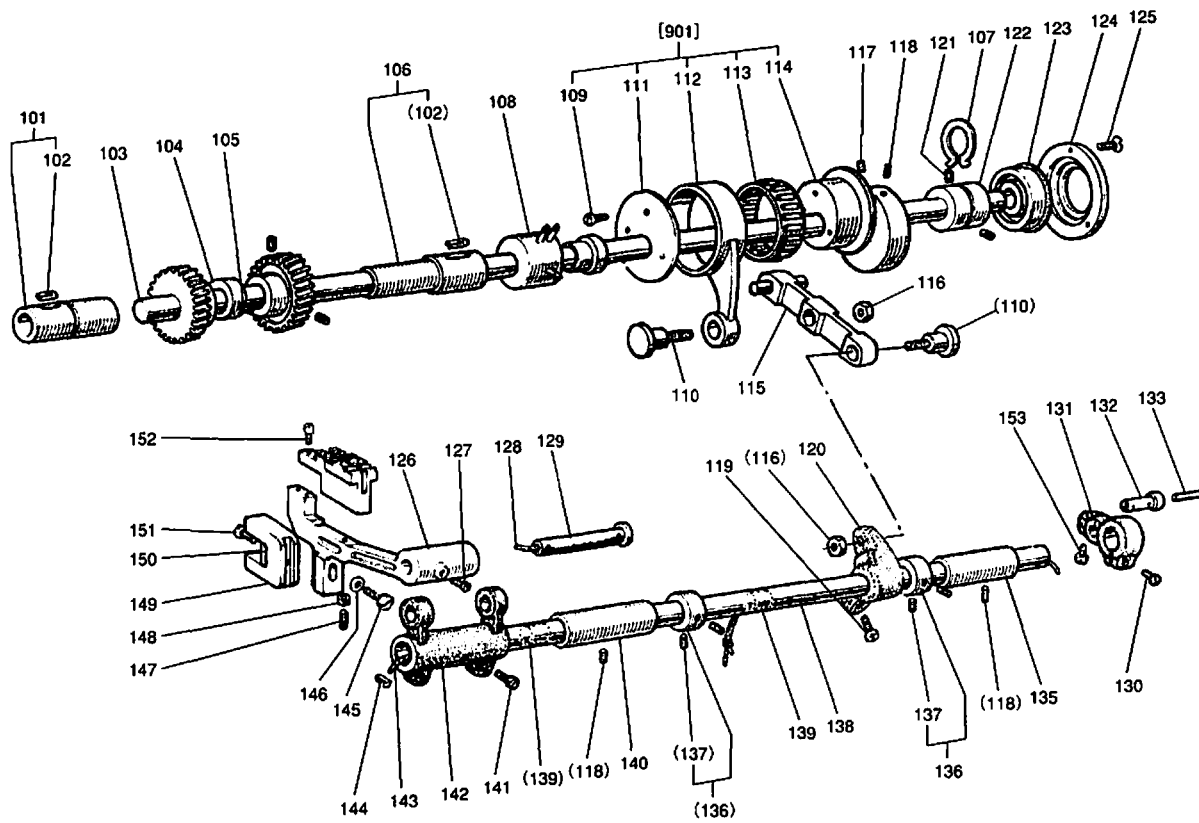

[J] 下軸・送り機構  
LOWER SHAFT & FEED ROCKING MOTION MECHANISM

Fig. No.	変更 No.	部品コード Parts No.	部品名	Description	使用個数 Amt. Req.				
					LT2-2240		LT2-2250		
					NOB	BOB	MTW	AIT	BIT
J101		MN70A0451	シタジクメタルヒタリクミタテ	LOWER SHAFT BUSHING LEFT (COMPLETE)	1	1	1	1	1
J102		MN70E1148	ヒモ	OIL WICK	2	2	2	2	2
J103		MN70A0450	シタジク	LOWER SHAFT	1	1	1	1	1
J104		MN70A0760	ハンソリソリン	FEED LIFTING CAM	1	1	1	1	1
J105		M91603001	トメネジ ホウサキ	SET SCREW 1/4 (40) X5	1	1	1	1	1
J106		MN70A0452	シタジクメタルミキクミタテ	LOWER SHFT BUSHING RIGHT (COMPLETE)	1	1	1	1	1
J107		M90320065	カクシメウシクヨウ20	RETAINING RING-C TYPE 20	1	1	1	1	1
J108		MN70E0453	シタジクメタルナカクミタテ	LOWER SHFT BUSHING MIDDLE (COMPLETE)	1	1	1	1	1
J109		M91109002	ヒラネジ	SCREW 11/64 (40) X7	3	3	3	3	3
J110		M91602015	ヒラネジ タンツキ	SCREW 1/4 (24) X22	2	2	2	2	2
J111			ザガネ	WASHER	1	1	1	1	1
J112			オクリロッド	FEED CONNECTING ROD	1	1	1	1	1
J113			ニードルベアリング	NEEDLE BEARING	1	1	1	1	1
J114			スィヘイオクリカム	LEVEL FEED CONNECTING CAM	1		1	1	
			スィヘイオクリカム	LEVEL FEED CONNECTING CAM		1			1
J115		MN70E0956	リンセツカンクミタテ	LINK (COMPLETE)	1	1	1	1	1
J116		M91601045	ナット	NUT 1/4 (24)	2	2	2	2	2
J117		M91513001	トメネジ	SET SCREW 15/64 (28) X10	1	1	1	1	1
J118		M91516001	トメネジ	SET SCREW 15/64 (28) X13	3	3	3	3	3
J119		M91506002	ヒラネジ	SCREW 15/64 (28) X14	1	1	1	1	1
J120		MN70A0273	オクリウテ ナカ	CONNECTING ROD CRANK (MIDDLE)	1	1	1	1	1
J121		M91602001	トメネジ	SET SCREW 1/4 (40) X4	2	2	2	2	2
J122		MN70A3750	ブツシュ	BUSHING	1	1	1	1	1
J123		MN70A2456	ジクウケ	BALL BEARING	1	1	1	1	1
J124		MN70A0771	オサエイタ	BEARING HOLDER	1	1	1	1	1
J125		M90902011	マルヒラネジ	SCREW 9/64 (40) X7	3	3	3	3	3
J126		MN70E0281	オクリウテ	FEED BAR	1	1			
		MP48A0281	オクリウテ	FEED BAR			1	1	1
J127		M95004021	ロツカガアナツキトメネジ	SCREW M5X5	1	1	1	1	1
J128		MN70E0148	ヒモ	OIL WICK	1	1	1	1	1
J129		MP47A1454	シク	FEED BAR SHAFT	1	1	1	1	1
J130		M91603003	マルヒラネジ	SCREW 1/4 (24) X16	1	1	1	1	1
J131		MN60A0279	オクリウテ	FEED ROCK SHAFT CRANK	1	1	1	1	1
J132		M90819063	ピン	PIN	1	1	1	1	1
J133		MF10E3148	ヒモ	OIL WICK	1	1	1	1	1
J134		M91603003	マルヒラネジ	SCREW 1/4 (24) X16	1	1	1	1	1
J135		MG50A0285	オクリウテクメタル	BUSHING FEED ROCK SHAFT	1	1	1	1	1
J136		MF80A0352	カラクミタテ	COLLAR	2	2	2	2	2
J137		M91602001	トメネジ	SET SCREW 1/4 (40) X4	4	4	4	4	4
J138		MN40A0491	スィヘイオクリウテ	FEED ROCK SHAFT	1	1	1	1	1
J139		MP40A2740	フェルト	FELT	2	2	2	2	2
J140		MF70A0286	オクリウテクメタル	BUSHING FOR FEED ROCK SHAFT	1	1	1	1	1
J141		M91204003	マルヒラネジ	SCREW 3/16 (28) X12	2	2	2	2	2
J142		MN40A0278	スィヘイオクリウテヒタリ	FEED ROCK SHAFT CRANK (LEFT)	1	1			
		MN50A0278	スィヘイオクリウテヒタリ	FEED ROCK SHAFT CRANK (LEFT)			1	1	1
J143		MF10E0148	ヒモ	OIL WICK	1	1	1	1	1
J144		MF80A0780	ホルダ	HOLDER	1	1	1	1	1
J145		M91516022	ホルト	BOLT 15/64 (28) X18	1	1	1	1	1
J146		M90831050	ミカキザガネ6	WASHER 6	1	1	1	1	1
J147		M93006020	コネジ	SCREW M3X14	1	1	1	1	1
J148		M90879045	ナット	NUT M3	1	1	1	1	1
J149		MN69A0744	フタマタ	FEED BAR CONNECTING FORK	1	1	1	1	1
J150		MN70A1740	フェルト	FELT	1	1	1	1	1
J151		M90804003	マルヒラネジ	SCREW 1/8 (44) X4	1	1	1	1	1
J152		M90803020	ロツカガアナツキホルト	BOLT 1/8 (40) X7	2	2	2	2	2
J153		M91203002	ヒラネジ	SCREW 3/16 (28) X15	1	1	1	1	1
J901		MN70E0290	スィヘイオクリカムロッドクミタテ	LEVEL FEED CONNECTING ROD (COMPLETE)	1		1	1	
		MN69E0290	スィヘイオクリカムロッドクミタテ	LEVEL FEED CONNECTING ROD (COMPLETE)		1			1

☑ カマ台機構  
 HOOK SADDLE MECHANISM

LT2-2240

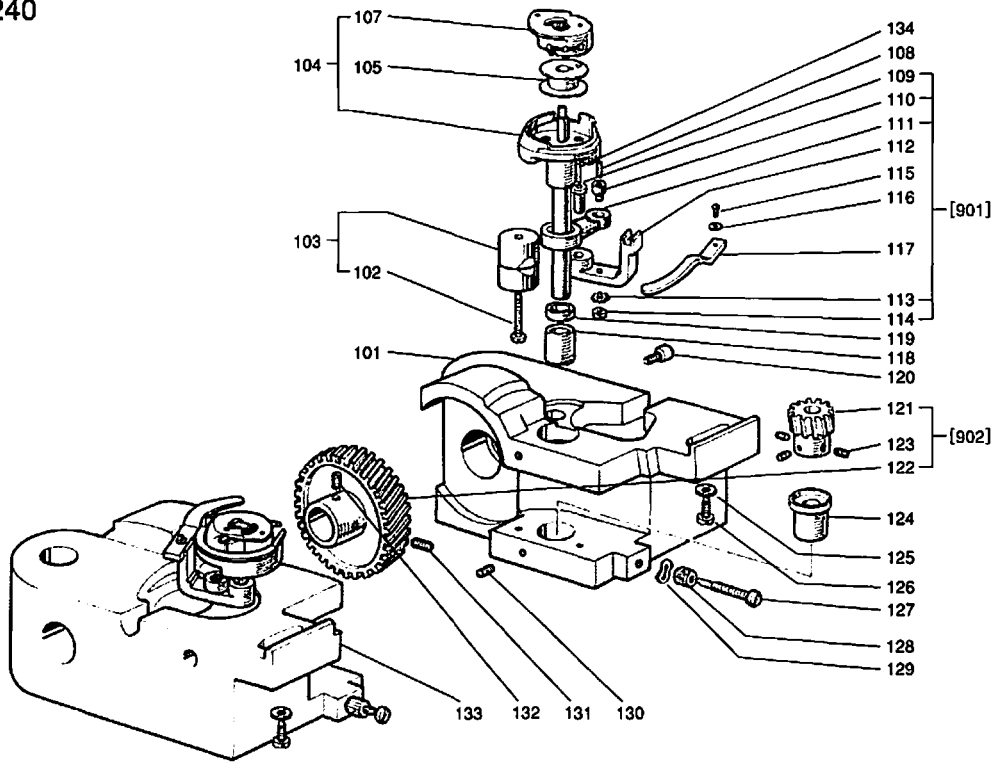

LT2-2250

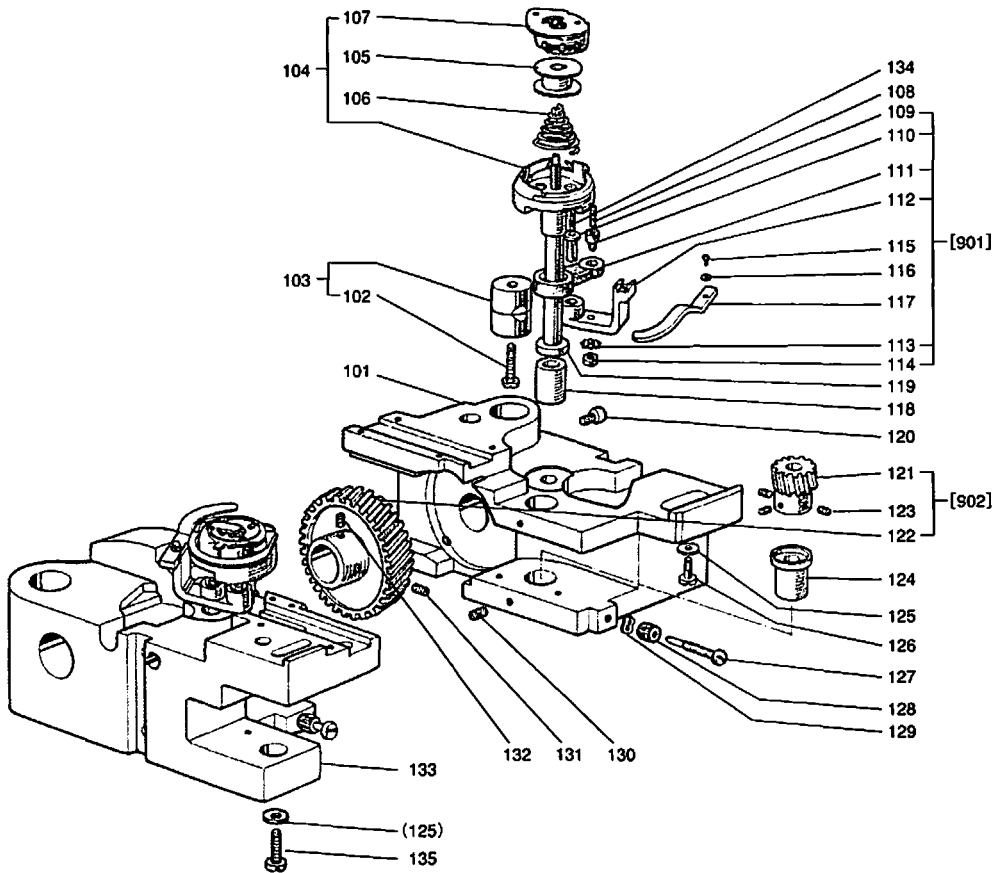

# [K] カマ台機構 HOOK SADDLE MECHANISM

Fig. No.	変更 Mod.	部品コード Parts. No.	部品名	Description	使用個数 Amt. Req.				
					LT2-2240 MOB	LT2-2240 BOB	LT2-2250 MTH	LT2-2250 AIT	LT2-2250 BIT
K101		MN70A0345	カマダ イミギ	HOOK SADDLE (RIGHT)	1				
		MN69A0345	カマダ イミギ	HOOK SADDLE (RIGHT)		1			
		MN82A0345	カマダ イミギ	HOOK SADDLE (RIGHT)			1		
		MN83A0345	カマダ イミギ	HOOK SADDLE (RIGHT)				1	1
K102		M91509002	ヒラネジ	SCREW 15/64 (28) X30	2	2	2	2	2
K103		MN70A2750	ブッシュクミタテ	BUSHING	2	2	2	2	2
K104		MN55A0120	カマクミタテ	HOOK COMPLETE	2				
		MN57A0120	カマクミタテ	HOOK COMPLETE		2			
		MN60E0120	カマクミタテ	HOOK COMPLETE			2		
		MN62E0120	カマクミタテ	HOOK COMPLETE				2	2
K105		MN40A0123	ボビン	BOBBIN	2				
		MN12B0123	ボビン	BOBBIN		2			
		MN50A1123	ボビン	BOBBIN			2		
		MN62A0123	ボビン	BOBBIN				2	2
K106		MN50A0245	エンスイハネ	SPRING			2		
		MN52A0245	エンスイハネ	SPRING				2	2
K107		MN55A0125	キャップ	BOBBIN CASE	2				
		MN57A0125	キャップ	BOBBIN CASE		2			
		MN60A0125	キャップ	BOBBIN CASE			2		
		MN62A0125	キャップ	BOBBIN CASE				2	2
K108		MF10A0148	ヒモ	OIL WICK	2	2	2	2	2
K109		MN10A0302	オープンナサエシケ	OPENER HOLDER PIN	2	2	2	2	2
K110		M91260030	トクシュネジ	SCREW	2	2	2	2	2
K111		MN10A0340	レンセツカン	LINK FOR OPENER HOLDER	2		2		
		MP40A0340	レンセツカン	LINK FOR HOOK SHAFT		2		2	2
K112		MN10A0301	オープンナサエ	BOBBIN CASE OPENER HOLDER	2		2		
		MN52A0301	オープンナサエ	BOBBIN CASE OPENER HOLDER		2		2	2
K113		M90501053	ハネサガネ M5	SPRING WASHER 5	2	2	2	2	2
K114		M91252045	ナツト	NUT 3/16 (32)	2	2	2	2	2
K115		M90910003	マルヒラネジ	SCREW 9/64 (40) X7	2	2	2	2	2
K116		M90401050	ザガネ	WASHER 4	2	2	2	2	2
K117		MN50A0300	オープンナー	OPENER	2		2		
		MN52A0300	オープンナー	OPENER		2		2	2
K118		MN80A0342	カマジクメタルウエ	HOOK SHAFT BUSHING (UPPER)	2		2		
		MN69A0342	カマジクメタルウエ	HOOK SHAFT BUSHING (UPPER)		2		2	2
K119		MN70A0476	スペーサ	SPACER	2		2		
		MN69A0476	スペーサ	SPACER		2		2	2
K120		M91201020	ロツカクアツキトメネジ	SOCKET SET SCREW 3/16 (28)	2	2	2	2	2
K121			ネジ ハウ ルマシヨウ	GEAR (COMPLETE)	2	2	2	2	2
K122			ネジ ハウ ルマダ イ	GEAR (COMPLETE)	2	2	2	2	2
K123		M91602001	トメネジ	SET SCREW 1/4 (40) X4	6	6	6	6	6
K124		MN70A0343	カマジクメタルシタ	HOOK SHAFT BUSHING (LOWER)	2	2	2	2	2
K125		M90551050	ミカキサガネ 6	WASHER 6	2	2	2	2	2
K126		M91652002	ヒラネジ	SCREW 1/4 (24) X23	2	2	1	1	1
K127		M91206030	トクシュネジ	SCREW 3/16 (28) X26	2	2	2	2	2
K128		M91206045	ツマミナツト	NUT 3/16 (28)	2	2	2	2	2
K129		M93005050	ハネサガネ	SPRING WASHER	2	2	2	2	2
K130		M91503001	トメネジ	SET SCREW 15/64 (28) X4.5	4	4	4	4	4
K131		M91606001	トメネジ	SET SCREW 1/4 (40) X6	2	2	2	2	2
K132		M91655001	トメネジ	SET SCREW 1/4 (24) X6.5	2	2	2	2	2
K133		MN70A0344	カマダ イヒダリ	HOOK SADDLE (LEFT)	1				
		MN69A0344	カマダ イヒダリ	HOOK SADDLE (LEFT)		1			
		MN72A0344	カマダ イヒダリ	HOOK SADDLE (LEFT)			1		
		MN74A0344	カマダ イヒダリ	HOOK SADDLE (LEFT)				1	1
K134		MF10E2148	ヒモ	OIL WICK	2	2	2	2	2
K135		M91658002	ヒラネジ	SCREW 1/4 (24) X30			1	1	1
K901		MN40E0301	オープンナーサエクミ	BOBBIN CASE OPENER HOLDER ASSY	2		2		
		MN10E0301	オープンナーサエクミ	BOBBIN CASE OPENER HOLDER ASSY		2		2	2
K902		MN70E0644	ネジ ハウ ルマクミタテ	GEAR (COMPLETE)	2	2	2	2	2

□ 糸切り機構 ( I )  
KNIFE MECHANISM ( I )

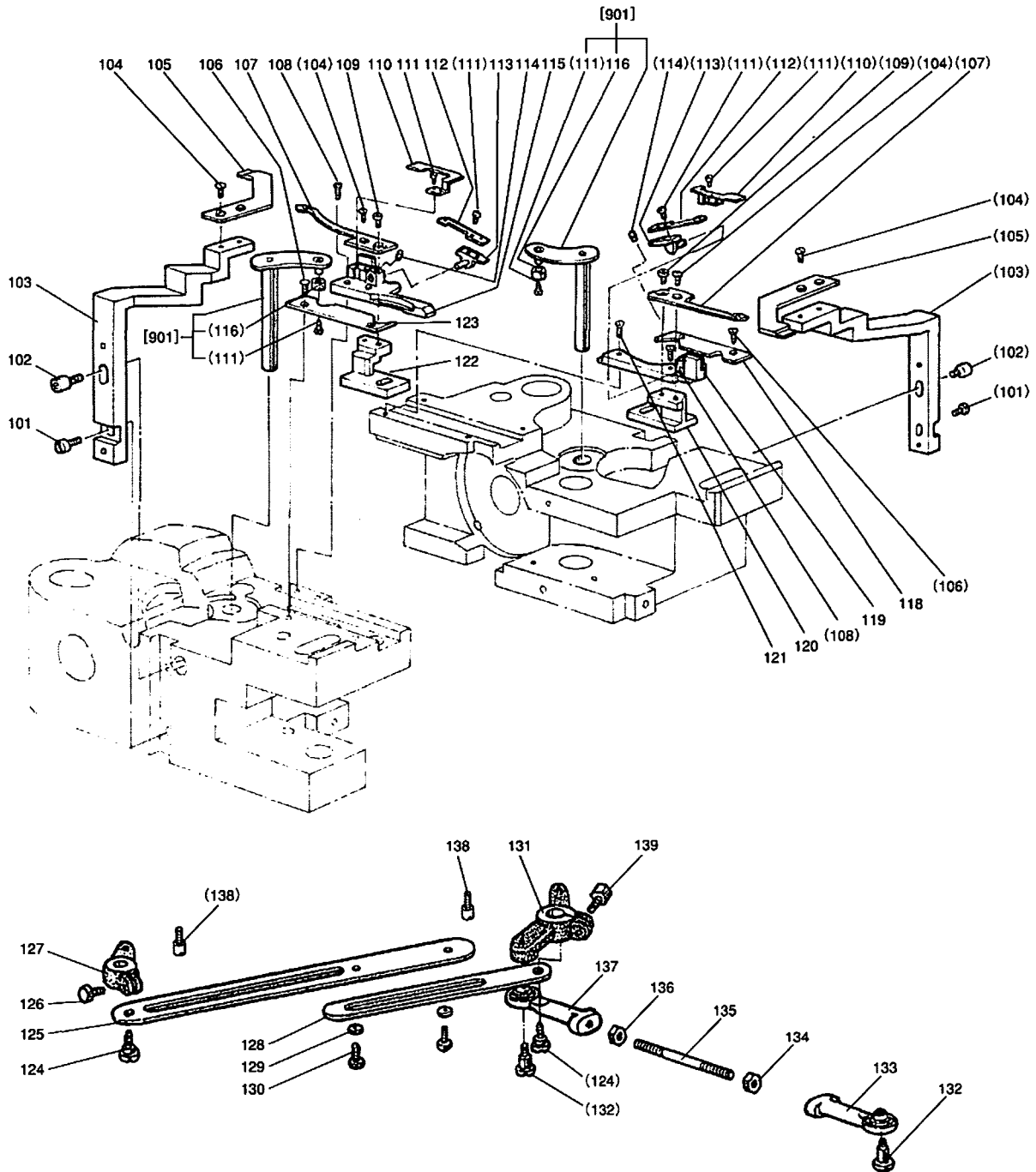

[L] 糸切り機構 (I)  
KNIFE MECHANISM (I)

Fig. No.	変更 No.	部品コード Parts No.	部品名	Description	使用個数 Amt. Req.				
					LT2-2240		LT2-2250		
					NOB	BOB	MTW	AIT	BIT
L101		M90911030	トクシュネジ	SPECIAL SCREW 9/64 (40)		2	2	2	
L102		M91106022	ロツカクアツキネジ	BOLT 11/64 (40) X16		2	2	2	
L103		MN50A0839	メストリツケダ	MOVED KNIFE HOLDER		2	2	2	
L104		M90907010	サラネジ	SCREW 9/64 (40) X5		6	6	6	
L105		MP41A0838	コテイメス	FIXED KNIFE		2	2	2	
L106		M90903010	サラネジ	SCREW 9/64 (40) X5		4	4	4	
L107		MP41B0838	イトウメス	MOVED KNIFE		2	2	2	
L108		M90801010	サラネジ	SCREW 1/8 (44) X10		3	3	3	
L109		M90944002	ヒラネジ	SCREW 9/64 (40) X4.5		2	2	2	
L110		MN82A0192	イタハネ	SPRING PLATE		2	2	2	
L111		M90605002	ヒラネジ	SCREW 3/32 (56) X3.8		6	6	6	
L112		MN82A1192	イタハネ	SPRING PLATE		2	2	2	
L113		MN82A0551	チヨウセツタイ	REGULATOR		2	2	2	
L114		M93003020	ロツカクアツキメネジ	SCREW M3X3		2	2	2	
L115		MN82A0154	アンナイカ	GUIDE (LEFT)		1	1	1	
L116		MN60A0411	コロ	ROLLER		2	2	2	
L117			レバ	LEVER		2	2	2	
L118		MN60A2742	フタ	COVER		1	1	1	
L119		MN82A1154	アンナイカ	GUIDE (RIGHT)		1	1	1	
L120		MN60A0837	メスタ	KNIFE PAD (RIGHT)		1	1	1	
L121		M90906010	サラネジ	SCREW 9/64 (40) X9.5		1	1	1	
L122		MN60A0836	メスタ	KNIFE PAD (LEFT)		1	1	1	
L123		MN60A1742	フタ	COVER		1	1	1	
L124		M91134015	ヒラネジ	HINGED SCREW M5X7.5		2	2	2	
L125		MP43A0910	リンク	LINK		1	1	1	
L126		M91508022	ネジ	BOLT 15/64 (28) X10		1	1	1	
L127		MN60A3228	ウデ	ARM		1	1	1	
L128		MN50A0910	リンク	LINK FOR REVERSE STITCHING		1	1	1	
L129		M90550050	ミガキ	WASHER 5		2	2	2	
L130		M91201022	ネジ	BOLT 3/16 (32) X9.5		2	2	2	
L131		MN60A1228	ウデ	ARM FOR KNIFE MECH.		1			
		MN60A2228	ウデ	ARM FOR KNIFE MECH.				1	1
L132		M91271015	ヒラネジ	HINGED SCREW M5		2	2	2	
L133		MB62A0975	ロツトエント	CONNECTING LINK		1	1	1	
L134		M91377045	ナット	NUT M5		1	1	1	
L135		M95004023	ウエコミネジ	STUD BOLT M5		1	1	1	
L136		M91374045	ナット	NUT M5		1	1	1	
L137		MN72A0975	ロツトエント	BALL JOINT		1	1	1	
L138		M91111033	ピン	PIN 11/64 (40)		2	2	2	
L139		M91509022	ネジ	BOLT		1	1	1	
L901		MN60A0950	レバ	LEVER ASSY		2	2	2	



系切り機構(Ⅱ)  
KNIFE MECHANISM (Ⅱ)

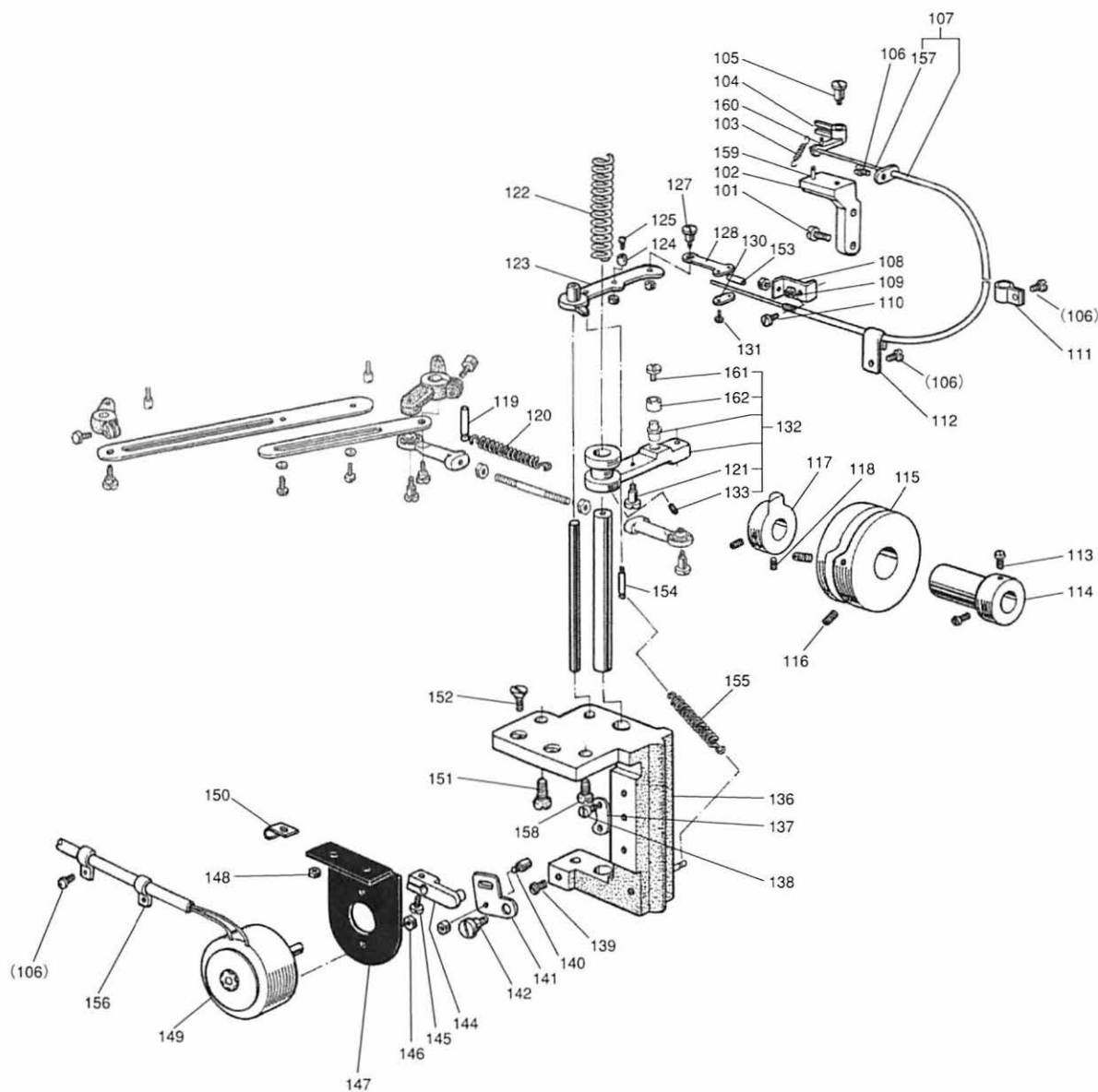

**[M] 系切り機構(Ⅱ)**  
**KNIFE MECHANISM(Ⅱ)**

Fig. No.	変更 Mod.	部品コード Parts. No.	部品名	Description	使用個数 Amt. Req.				
					LT2-2240	LT2-2250	HOB	BOB	M/T#
M101		M91110002	ヒラネジ	SCREW 11/64 (40) X8			2	2	2
M102		MN60A0172	イトユルメダ イ	THREAD RELEASING BRACKET			1	1	1
M103		MN60A6572	ツルマキハネ	SPRING			1	1	1
M104		MN60A0173	イトユルメ	THREAD RELEASING PLATE			1	1	1
M105		M91112015	ヒラネジ タンツキ	HINGED SCREW 11/64 (40) X6.5			1	1	1
M106		M91106004	ブ ラマイネジ	SCREW 11/64 (40) X8			4	4	4
M107		MN60E0746	フレキシブルワイヤクミタテ	FLEXIBLE WIRE ASSY			1	1	1
M108		MN72A0601	トリツケイタ	SCREW M6X8			1	1	1
M109		M91373045	ナット	NUT M5X0.8			2	2	2
M110		M91251015	ヒラネジ タンツキ	HINGED SCREW 3/16 (32) X3.5			1	1	1
M111		MN60A0620	ナイロンクリップ	NYLON CLIP			1	1	1
M112		M94003099	ナイロンクリップ	NYLON CLIP AB-3N			1	1	1
M113		M91516002	ヒラネジ	SCREW 15/64 (28) X8.5			2	2	2
M114		MN72A0750	ブ ツシュ	BUSHING			1	1	1
M115		MN50A0350	イトキリカム	CAM FOR TRIMMER ACTUATOR			1	1	1
M116		M91602020	ロツカアナツキメネジ	SOCKET SET SCREW 1/4 (40) X10			2	2	2
M117		MN72A0350	カム	CAM			1	1	1
M118		M91055020	ロツカアナツキメネジ	SOCKET SET SCREW M4X4			1	1	2
M119		M95007067	ミゾ ツキピン	PIN			1	1	1
M120		MP60A3572	ツルマキハネ	SPRING			1	1	1
M121		M91111015	ヒラネジ タンツキ	HINGED SCREW 11/64 (40) X6.2			1	1	1
M122		MN60A5572	ツルマキハネ	SPRINGCLIP			1	1	1
M123		MN60E0950	イトユルメレバークミタテ	THREAD RELEASING LEVER ASSY			1	1	1
M124		MN50A0411	コロ	ROLLER			1	1	1
M125		M91131015	ヒラネジ タンツキ	HINGED SCREW 11/64 (40) X3.6			1	1	1
M126		M91107045	ナット	NUT 11/64 (40)			1	1	1
M127		M91231015	ヒラネジ タンツキ	HINGED SCREW 3/16 (28) X9			1	1	1
M128		MN72A1601	トリツケイタ	MOUNTING PLATE			1	1	1
M129		M91201045	ナット	NUT 3/16 (28)			1	1	1
M130		MF36A0750	ブ ツシュ	FLEXIBLE WIRE CONNECTING BRACKET			1	1	1
M131		M90825002	ヒラネジ	SCREW 1/8 (44) X10			2	2	2
M132		MN60A0886	ヨウトウウデクミタテ	CRANK FOR KNIFE DRIVING			1	1	1
M133		M91001020	ロツカアナツキメネジ	SCREW 11/64 (40) X5			2	2	2
M134		MN50A3454	ジク	SHAFT			1	1	1
M135		MN60A0454	ジク	SHAFT			1	1	1
M136		MP66A0603	トリツケイタ	MOUNTING BASE			1	1	1
M137		MN50A0477	ストツバ	STOPPER			1	1	1
M138		M91109002	ヒラネジ	SCREW 11/64 (40) X7			2	2	2
M139		M91102002	ヒラネジ	SCREW 11/64 (40) X8.5			1	1	1
M140		M91111033	ピンネジ	PIN 11/64 (40)			1	1	1
M141		MN50A3950	レバ	LEVER			1	1	1
M142		M91103016	マルヒラネジ タンツキ	HINGED SCREW 11/64 (40) X4.5			1	1	1
M144		MP61E0228	ウデクミタテ	ARM FOR ROTARY SOLENOID			1	1	1
M145		M91112002	ヒラネジ	SCREW 11/64 (40) X12			1	1	1
M146		M91101045	ナット	NUT 11/64 (40)			1	1	1
M147		MN50A3601	トリツケイタ	SETTING PLATE			1	1	1
M148		M91373045	ナット	NUT M5			2	2	2
M149		MP61E0519	ソレノイドクミタテ	SOLENOID FOR THREAD TRIMMER (24V)			1	1	1
M150		MN50A0780	ホルダ	HOLDER			1	1	1
M151		M91603003	マルヒラネジ	SCREW 1/4 (24) X16			1	1	1
M152		M95001037	Pサラネジ	SCREW M5X16			2	2	2
M153		MN72A1750	ブ ツシュ	BUSHING			1	1	1
M154		M91111030	トクシユネジ	SPECIAL SCREW 11/64 (40) X4			1	1	1
M155		MN50A3572	ツルマキハネ	COIL SPRING			1	1	1
M156		MF10A0689	ホルダ	HOLDER			2	2	2
M157		MN50A0746	フレキシブルワイヤ	FLEXIBLE WIRE			1	1	1
M158		M91602003	マルヒラネジ	SCREW 1/4 (24) X13			1	1	1
M159		M91004067	ミゾ ツキピン BXカタ	PIN			1	1	1
M160		M91005067	ミゾ ツキピン BXカタ	PIN			1	1	1
M161		M90816002	ヒラネジ	SCREW 1/8 (44) X4.5			1	1	1
M162		MN50A1411	コロ	ROLLER			1	1	1

N タッチバックおよび検出器機構  
 TOUCH BACK, COMPENSATION STITCHING & DETECTOR MECHANISM

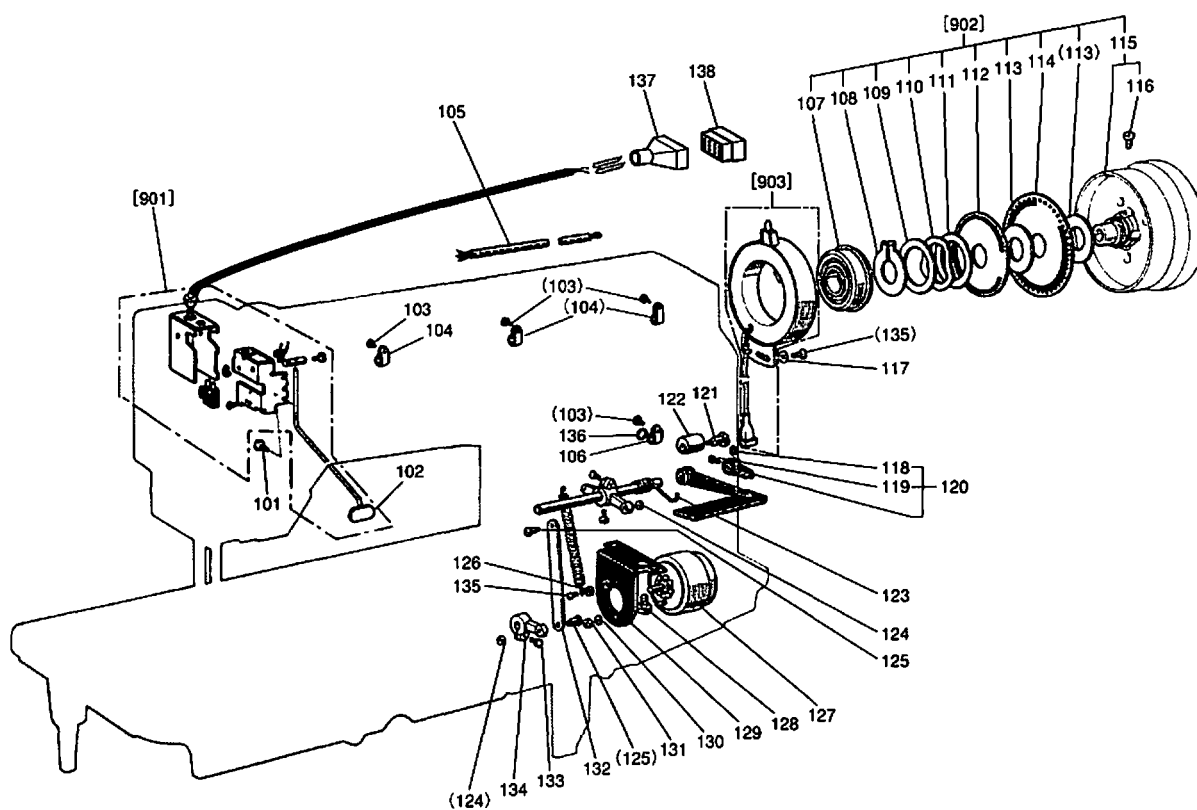

[N] タッチバックおよび検出器機構  
TOUCH BACK, COMPENSATION STITCHING & DETECTOR MECHANISM

Fig. No.	変更 No.	部品コード Parts. No.	部品名	Description	使用個数 Amt. Req.				
					LT2-2240	LT2-2250			
					MOB	BOB	MTW	AIT	BIT
N101		M91109004	ザ'ガ'ネツキ'ブ'ラマイネジ'	SCREW 11/64 (40) X9			3	3	3
N102		MN50A4950	レバ'ークミタテ'	LEVER			1	1	1
N103		M91111004	ブ'ラマイネジ'	SCREW 11/64 (40) X10			4	4	4
N104		M94003099	ナイロンクリップ'	NYLON CLIP AB-3N				3	3
		MN60A0620	ナイロンクリップ'	NYLON CLIP AB-5N			3		
N105		M97003095	アースセンクミタテ'	EARTH CORD ASSY.			1	1	1
N106		MB60A1620	ナイロンクリップ'	SCREW M6X8			1	1	1
N107		MN10A1456	ジ'ウケ'	BALL BEARING			1	1	1
N108		M90330065	カ'タメワ'	RETAINING RING-C TYPE 30			1	1	1
N109		M93001050	ザ'ガ'ネ'	WASHER			1	1	1
N110		MF01A0259	ハンヤハ'ン'オサエス'リング'	SUPPORTER SPRING			1	1	1
N111		MF01A1476	スベ'ーサB'	SPACER B			2	2	2
N112		MN72A1694	ハンヤハ'ン'F20'	SPEED COMMAND DISC F20			1	1	1
N113		MF01A0476	スベ'ーサA'	SPACER A			1	1	1
N114		MN82A0694	ハンヤハ'ン'F11'	SPEED COMMAND DISC F11			1	1	1
N115		MN72E1682	プ'ーリクミタテ'	PULLEY (COMPLETE)			1	1	1
N116		M91520002	ヒラネジ'	SCREW 15/64 (28) X12			2	2	2
N117		M93002050	ザ'ガ'ネ'	WASHER			1	1	1
N118		M91506001	トメネジ'	SET SCREW 15/64 (28) X6			1	1	1
N119		M91519002	ヒラネジ'	SCREW 15/64 (28) X7.5			1	1	1
N120		MN72A1950	レバ'ークミタテ'	LEVER (COMPLETE)			1	1	1
N121		M91516015	ヒラネジ'ダ'ンツキ'	HINGED SCREW 15/64 (28) X6			1	1	1
N122		MN50A0417	ゴ'ムワ'	RUBBER RING			1	1	1
N123		MP61A0729	ヒネリハ'ネ'	SPRING			1	1	1
N124		M91502045	ナツト'	NUT 15/64 (28)			2	2	2
N125		M91517015	ヒラネジ'ダ'ンツキ'	HINGED SCREW 15/64 (28) X13			2	2	2
N126		M91101045	ナツト'	NUT 11/64 (40)			1	1	1
N127		MN72E1519	ソレノイド'クミタテ'	SOLENOID (24V)			1	1	1
N128		M98005022	ボ'ルト'	BOLT M8X12			2	2	2
N129		MN50A2601	トリツケイタ'	SETTING PLATE			1	1	1
N130		M90601053	ハ'ネサ'ガ'ネ'	SPRING WASHER 6			2	2	2
N131		M91571045	ナツト'	NUT M6			2	2	2
N132		MN50A2910	リンク'	LINK			1	1	1
N133		M91502022	ボ'ルト'	BOLT 15/64 (28) X16			1	1	1
N134		MN50A5228	ウテ'	ARM FOR TOUCH BACK SOLENOID			1	1	1
N135		M91106004	ブ'ラマイネジ'	SCREW 11/64 (40) X8			2	2	2
N136		M90421050	ミカ'キザ'ガ'ネ'	WASHER 4			1	1	1
N137		MG68A0366	コネクタ'キヤツブ'	CONNECTOR CAP			1	1	1
N138		M91018099	コネクタ'	CONNECTOR 1360-P			1	1	1
N901		MN82E0534	タッチスイツチクミタテ'	TOUCH SWIHT (COMPLETE)			1	1	1
N902		MN72E0682	プ'ーリクミタテ'	PULLY COMPLETE			1	1	1
N903		ME20A0406	ケンシユツキ XC-K-2000'	DETECTOR BRACKET (COMPLETE)			1	1	1

□ワイパー機構  
WIPER MECHANISM

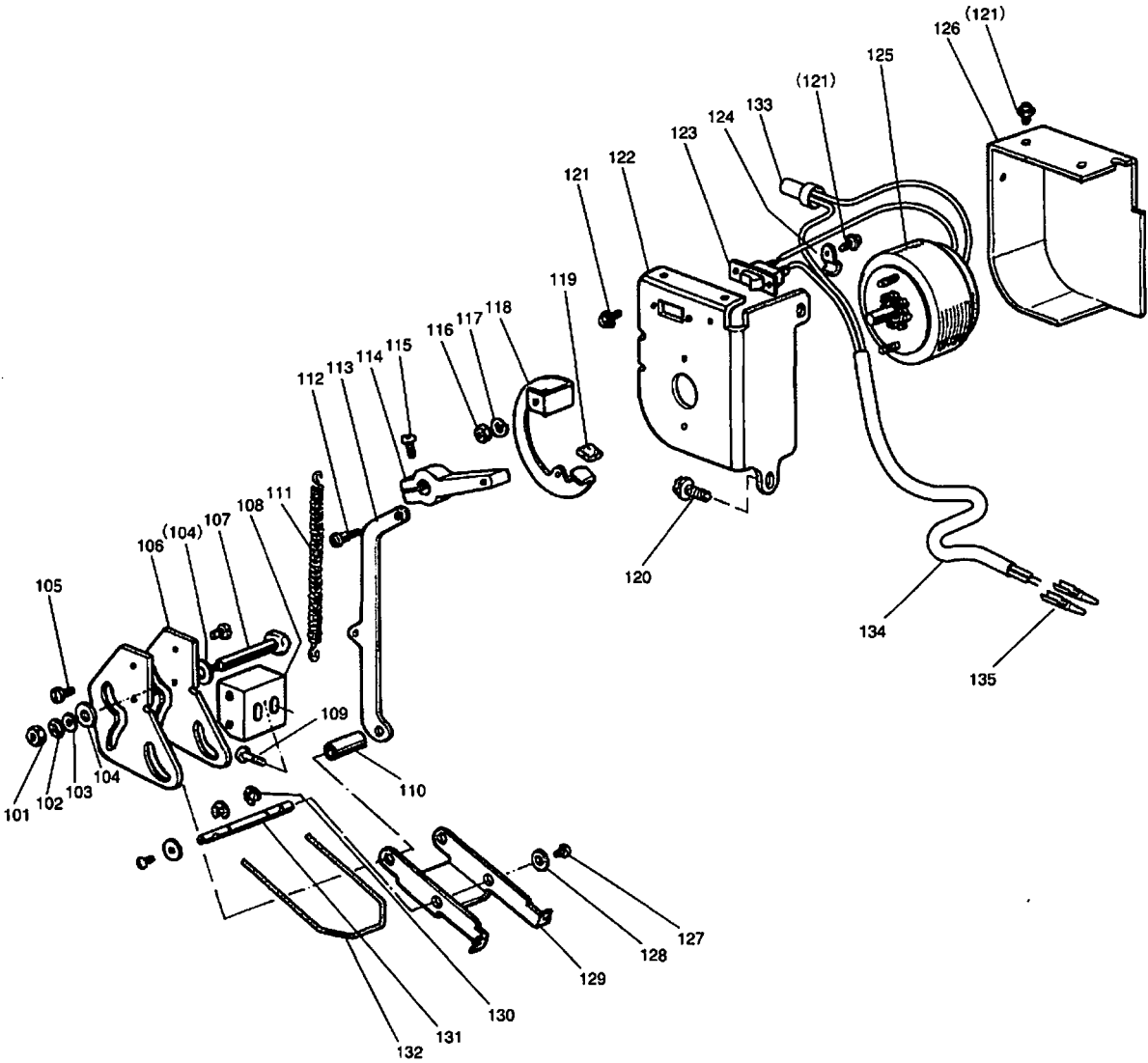

[P]ワイパー機構  
WIPER MECHANISM

Fig. No.	変更 Mod.	部品コード Parts.No.	部品名	Description	使用個数 Amt. Req.				
					LT2-2240		LT2-2250		
					MOS	BOB	MTW	AIT	BIT
P101		M90872045	ナット	NUT M3					1
P102		M90103053	ハネサガネ3	SPRING WASHER 3					1
P103		M90312050	サガネ 3	WASHER 3					1
P104		M90403050	ミカネサガネ	WASHER 4					2
P105		M91109002	ヒラネジ	SCREW 11/64 (40) X7					4
P106		MN72E0327	カムイタキミタテ	CAM PLATE (COMPLETE)					1
P107		MN72A0454	ツバツキシク	SHAFT M3X3.5					1
P108		MN72A0982	ワイパーグアイ	WIPER STAND					1
P109		M91106003	マルヒラネジ	SCREW 11/64 (40) X20					2
P110		MN72A0476	スペーサ	SPACER					1
P111		MN50A2572	ツルマキバネ	COIL SPRING					1
P112		M90929015	ヒラネジ タンツキ	SCREW 9/64 (40) X7.4					1
P113		MN72A0910	リンク	LINK					1
P114		MN72A0981	ワイパーウテ	WIPER CRANK					1
P115		M91117002	マルヒラネジ	SCREW 11/64 (40) X13					1
P116		M91002045	ナット	NUT M4					2
P117		M90401053	ハネサガネ 4	SPRING WASHER 4					2
P118		MN72A0477	ストッパイタ	STOPPER PLATE					1
P119		MN72A0397	クッション	CUSION					1
P120		M91109004	サガネツキフ ラマイネジ	SCREW-PW 11/64 (40) X9					2
P121		M90308037	SW, PW3X6	SCREW SW-PW M3X6					6
P122		MN72A2601	ソレノイド トリツケイタ	SOLENOID PLATE					1
P123		MF40E2484	ハトウスイツチ	SWITCH FOR WIPER					1
P124		MF00A1780	ホルダ	HOLDER					1
P125		MN72E2519	ロータリソレノイド	SOLENOID FOR WIPER (24V)					1
P126		MN72A0339	カバー	COVER					1
P127		M90806002	ヒラネジ	SCREW 1/8 (44) X6					2
P128		M90551050	ユガタマルサガネ6	WASHER 6					2
P129		MN72A0470	ワイパースベリイタ	WIPER SLIDE PLATE					1
P130		M90704065	エガタメワ 4	E-TYPE STOP RING 4					2
P131		MN72A1454	ワイパーシク	WIPER SHAFT					1
P132		MN72A4980	ワイパー	WIPER					1
P133		M91019099	ヘイタンセツツカシ JST 1-SD	CONNECTING					1
P134		M97357099	ビニルケーブル	CABLE					1
P135		M93003099	ピン 1380TL	TERMINAL 1380TL					2

給油機構  
OIL LUBRICATION MECHANISM

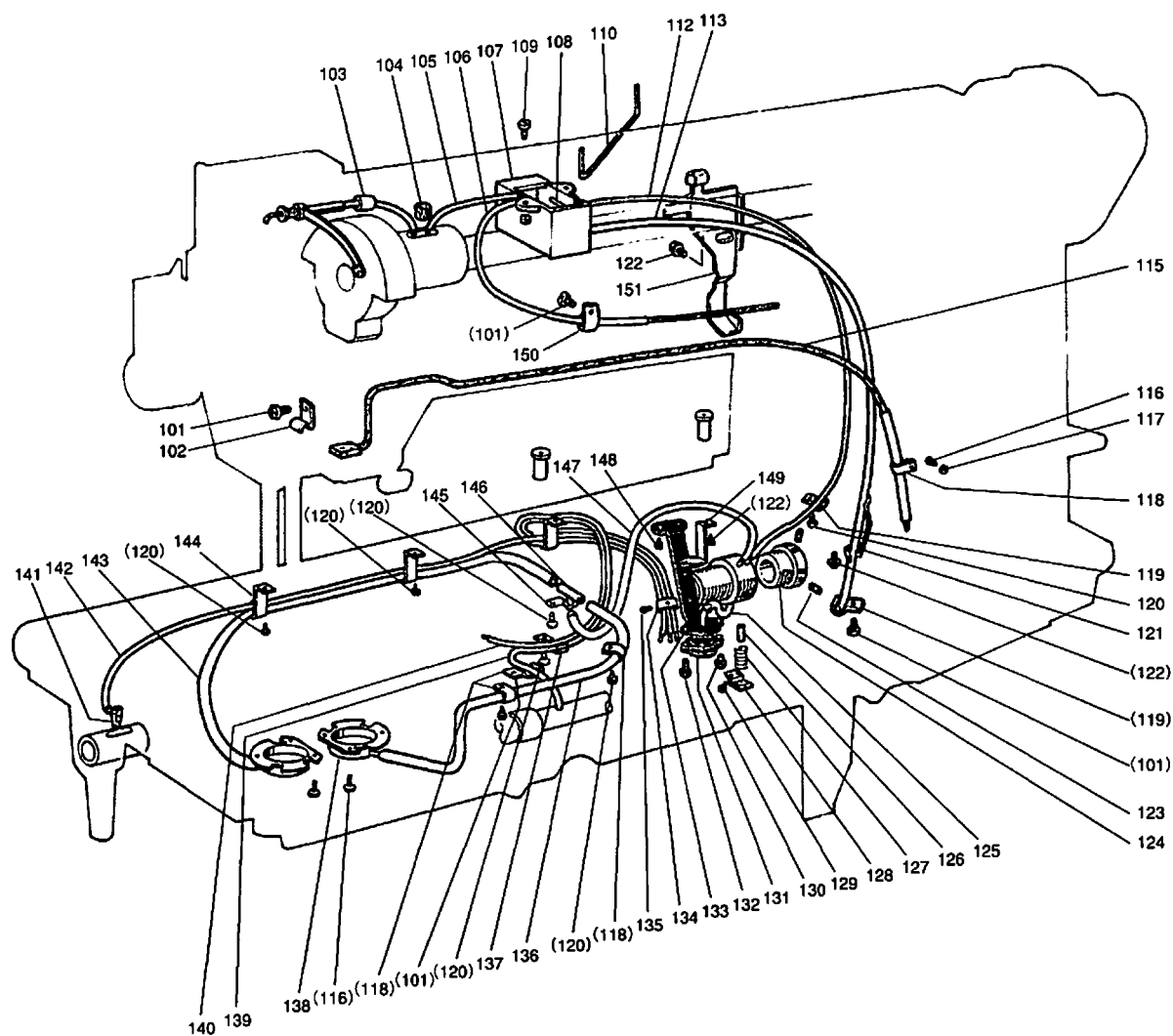

[Q] 給油機構  
OIL LUBRICATION MECHANISM

Fig. No.	変更 Mod.	部品コード Parts. No.	部品名	Description	使用個数 Amt. Req.				
					LT2-2240	LT2-2250			
					MOB	BOB	M/TW	A/T	BIT
Q101		M91106004	ブライネジ	SCREW 11/64 (40) X8	3	3	3	3	3
Q102		MF70A0689	ホルダ	HOLDER	1	1	1	1	1
Q103		MN70A3688	パイプ	PIPE	1	1	1	1	1
Q104		MP40A3740	フェルト	FELT	1	1	1	1	1
Q105		MN70E0688	パイプヒモクミタテ	OIL PIPE & WICK COMPLETE	1	1	1	1	1
Q106		MN70E1688	パイプヒモクミタテ	OIL PIPE & WICK COMPLETE	1	1	1	1	1
Q107		MN70E0138	オイルタンククミタテ	OIL TANK COMPLETE	1	1	1	1	1
Q108		M90603064	スプリングピン	SPRING PIN	1	1	1	1	1
Q109		M91402010	P オットウサラネジ	SCREW M4X16	2	2	2	2	2
Q110		MN70A0780	ホルダ	HOLDER	1	1	1	1	1
Q111		MN70E7688	パイプ	PIPE 3DX5D-480L	1	1	1	1	1
Q112		MN70E8688	パイプ	PIPE	1	1	1	1	1
Q113		MN70E3688	パイプヒモクミタテ	PIPE & FELT COMPLETE	1	1	1	1	1
Q114		M90903002	ヒラネジ	SCREW 9/64 (40) X6.5	7	7	7	7	7
Q115		M90304053	ハネサガネ 3.5	SPRING WASHER 3.5	1	1	1	1	1
Q116		MF10A0689	ホルダ	HOLDER	4	4	4	4	4
Q117		MN70A1780	ホルダ	HOLDER	2	2	2	2	2
Q118		M91107002	ヒラネジ	SCREW 11/64 (40) X5.5	7	7	6	6	6
Q119		MN70A2780	ホルダ	HOLDER	1	1	1	1	1
Q120		M91109004	サガネツキブライネジ	SCREW-PW 11/64 (40) X9	3	3	3	3	3
Q121		M91111001	トメネジ	SET SCREW 11/64 (40) X10	2	2	2	2	2
Q122		MN40A0750	ブツシュ	BUSHING FOR OIL RETURN PUMP	1	1	1	1	1
Q123		MP40A2688	パイプ	OIL PIPE	1	1	1	1	1
Q124		M95007063	トクシユピン	PIN	1	1	1	1	1
Q125		MN40A1572	コイルマキハネ	COIL SPRING	1	1	1	1	1
Q126		MN40A0705	ハネサエ	SPRING HOLDER	1	1	1	1	1
Q127		M90805002	ヒラネジ	SCREW 1/8 (44) X4.5	1	1	1	1	1
Q128		M90944003	マルヒラネジ	SCREW 9/64 (40) X5	1	1	1	1	1
Q129		MP60A0337	フィルタ	FILTER	1	1	1	1	1
Q130		M90905003	マルヒラネジ	SCREW 9/64 (40) X7	1	1	1	1	1
Q131		MN70E1601	トリツケイタクミタテ	BASE PLATE COMPLETE	1	1	1	1	1
Q132		MP40A4689	ホルダ	HOLDER	1	1	1	1	1
Q133		M90906002	ヒラネジ	SCREW 9/64 (40) X4.5	1	1	1	1	1
Q134		MN70E7688	パイプ	PIPE	1	1	1	1	1
Q135		MQ60A2780	ホルダ	HOLDER	1	1	1	1	1
Q136		MN50E0742	フタクミタテ	COVER	2	2	2	2	2
Q137		MN70E4688	パイプヒモクミタテ	OIL PIPE & WICK COMPLETE	1	1	1	1	1
Q138		MN70E5688	パイプヒモクミタテ	OIL PIPE & WICK COMPLETE	1	1	1	1	1
Q139		MN70E0148	ヒモ	OIL WICK	3	3	3	3	3
Q140		MN70E6688	パイプヒモクミタテ	OIL PIPE & WICK COMPLETE	1	1	1	1	1
Q141		MN70E7688	パイプ	PIPE 3DX5D-480L	1	1	1	1	1
Q142		MN70A5780	ホルダ	HOLDER	3	3	2	2	2
Q143		MN70A8780	ホルダ	HOLDER	1	1	1	1	1
Q144		MP40A0571	アブラツキテ	OIL PIPE JOINT	1	1	1	1	1
Q145		MN70E7688	パイプ	PIPE	1	1	1	1	1
Q146		M91118002	ヒラネジ	SCREW 11/64 (40) X10	2	2	2	2	2
Q147		MN70A0429	ササエイタ	HOLDING PLATE	1	1	1	1	1
Q148		MF40A1780	ホルダ	HOLDER	1	1	1	1	1
Q149		MN70A9780	ホルダ	HOLDER	1	1	1	1	1





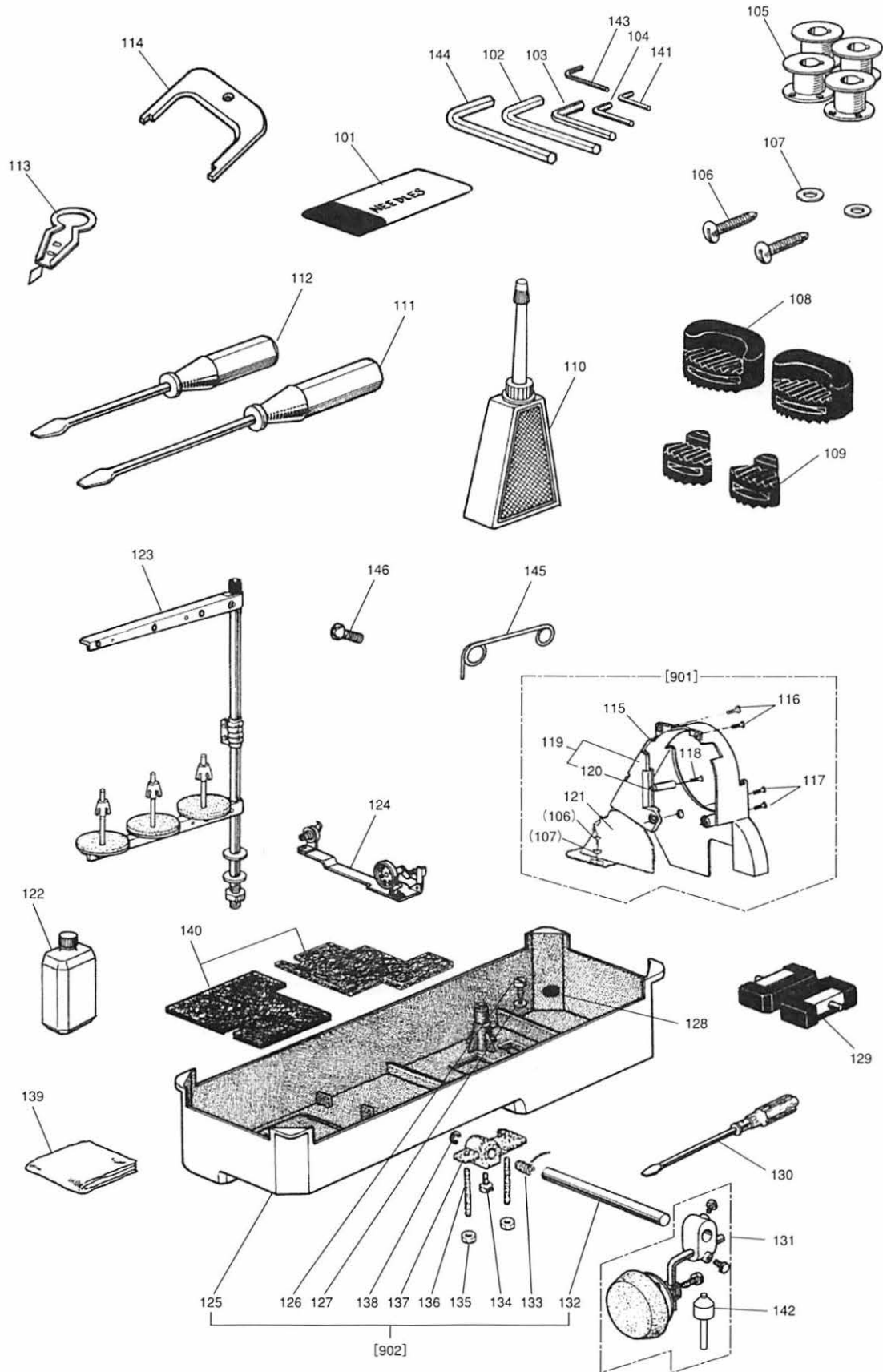









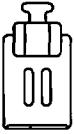

Ⓜ 付属品  
ACCESSORIES

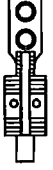
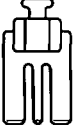

[R] 付属品  
ACCESSORIES

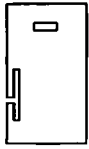
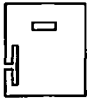
Fig. No.	変更 Mod.	部品コード Parts. No.	部品名	Description	使用個数 Amt. Req.				
					LT2-2240		LT2-2250		
					MOB	BOB	M/TW	A/T	B/T
R101		MV01A0128	ミシンハリ DPX5-14	NEEDLE (DPX5-14)	6		6	6	
		MN42A0128	ミシンハリ DPX5-21	NEEDLE (DPX5-21)		6			6
R102		MS01A0976	スパナ ロツカクホウ	SOCKET WRENCH 3			1	1	1
R103		MS02A1976	スパナ ロツカクホウ	SOCKET WRENCH 2.5	1	1	1	1	1
R104		MS02A0976	スパナ ロツカクホウ	SOCKET WRENCH 2			1	1	1
R105		MN40A0123	ホビーン	BOBBIN	4				
		MN12B0123	ホビーン	BOBBIN		4			
		MN50A1123	ホビーン	BOBBIN			4		
		MN62A0123	ホビーン	BOBBIN				4	4
R106		M90409041	マルモクネジ	SCREW 4.5X20	4	4	4	4	4
R107		M90511050	ミカネジガネ 5	WASHER 5	4	4	4	4	4
R108		MN70A0419	ホウシヨゴム	VIBRATION PREVENTING RUBBER	2	2	2	2	2
R109		MN70A1419	ホウシヨゴム	VIBRATION PREVENTING RUBBER	2	2	2	2	2
R110		MF60A0137	アブラサシ	OILER	1	1	1	1	1
R111		MB02A0608	ネジマワシ(チュウ)	SCREW DRIVER (MIDDLE)	1	1	1	1	1
R112		MB02A1608	ネジマワシ(ショウ)	SCREW DRIVER (SMALL)	1	1	1	1	1
R113		MN10A0172	イトオシキクミタテ	THREAD A NEEDLE KIT	1	1	1	1	1
R114		MF01A0565	カクトチヨウセイク	SPEED COMMAND DISC ADJUSTING PLATE			1	1	1
R115		MN70A5776	ベルトカバー-1	BELT COVER	1	1	1	1	1
R116		M91109004	ザガネツキアライネジ	SCREW-PW 11/64 (40) X9	2	2	2	2	2
R117		M91508004	アライネジ	SCREW 15/64 (28) X8	2	2	2	2	2
R118		M91075004	SW-PWツキアライハネジ	SCREW M4X14	1	1	1	1	1
R119		MP47A1776	ベルトカバー-2	BELT COVER 2	1	1	1	1	1
R120		M91002045	ナット	NUT M4	1	1	1	1	1
R121		ME10E1776	ベルトカバー	BELT COVER	1	1			
		MN72A1776	ベルトカバー	BELT COVER			1	1	1
R122		MN70E0149	アブラカン	OIL CAN	1	1	1	1	1
R123		MP48E0193	イトタテダイクミタテ 3	COTTON STAND	1	1	1	1	1
R124		MN70E0190	イトマキシカケ	BOBBIN WINDER	1				
		MN69E0190	イトマキシカケ	BOBBIN WINDER		1			
R125		MN40A1139	アブラソウ	OIL RESERVOIR	1	1	1	1	1
R126		M92002002	ヒラネジ	SCREW 5/16 (28) X10	1	1	1	1	1
R127		M97001052	トクシユガネ	WASHER 8	1	1	1	1	1
R128		M90701099	OP-S ジンヤク	MAGNET BLOCK	1	1	1	1	1
R129		MF01E0418	チヨウハンセット	HINGE WITH RUBBER CUSHION	2	2	2	2	2
R130		MF00A0608	ネジマワシ(ダイ)	SCREW DRIVER (LARGE)	1	1	1	1	1
R131		MN40E0727	コモノフヒンセット	KNEE LIFTER ASSY	1	1	1	1	1
R132		MF20A1723	ヒザアゲシク	KNEE LIFTER BAR	1	1	1	1	1
R133		MF20A1729	ヒネリバネ	TWIST SPRING	1	1	1	1	1
R134		M92005031	ホルト	BOLT	1	1	1	1	1
R135		M91501045	ナット	NUT 15/64 (28)	2	2	2	2	2
R136		M91520001	トメネジ	SET SCREW 15/64 (28) X28	2	2	2	2	2
R137		MN70A0724	ヒザアゲウテ	KNEE LIFTER CRANK	1	1	1	1	1
R138		M90515065	エカチメウ 9	RETAINING RING (ETYPE) 9	1	1	1	1	1
R139		MN70A0734	ビニールカバー	VINYL COVER	1	1	1	1	1
R140		MN70E0740	フェルトクミタテ	FELT	1	1	1	1	1
R141		MN25A0479	スパナ ロツカクホウ	SOCKET WRENCH 1/16	1	1	1	1	1
R142		MN40A0578	ヒザアゲヒンクミタテ	KNEE LIFTER LIFTING ROD	1	1	1	1	1
R143		MS10A0976	スパナ ロツカクホウ 1.5	SOCKET WRENCH 1.5	1	1	1	1	1
R144		MS01A1976	スパナ ロツカクホウ 4	SOCKET WRENCH 4	1	1	1	1	1
R145		MN82A0180	イトアンナイ	THREAD GUIDE			1	1	1
R146		M90350037	アライネジ	SCREW M3X6			1	1	1
R901		MN70E2776	ベルトカバー-セット	BELT COVER ASSY.	1	1			
		MN72E2776	ベルトカバー-セット	BELT COVER ASSY.			1	1	1
R902		MN70E0139	アブラソウセット	OIL RESERVOIR ASSY.		1			1
		MN70E1139	アブラソウセット	OIL RESERVOIR ASSY.	1		1		

☑ ゲージ部品表 ( I ) LT2-2240  
GAUGE PARTS LIST ( I )











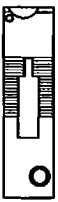



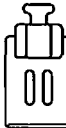

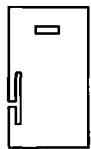
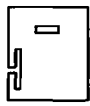

針板 Needle Plate		送り Feed Dog			押工 Presser Foot	針ダキ Needle Clamp	スベリ板(左) Slide Plate (L)	スベリ板(右) Slide Plate (R)
MOB	BOB	MOB	BOB	オプション仕様 (薄物用)				
 1/8	 針穴 φ1.9 歯ピッチ 1.7 1/8	 針穴 φ2.5 歯ピッチ 1.7 1/8	 針穴 φ1.6 歯ピッチ 1.15 1/8		 MOB 1/8~1/2			
 3/16~3/8	 針穴 φ1.9 歯ピッチ 1.7 3/16~3/8	 針穴 φ2.5 歯ピッチ 1.7 3/16~3/8	 針穴 φ1.6 歯ピッチ 1.15 3/16~3/8		 MOB 1/8~1/2	 1/8~1/2	 1/8~1/2	 1/8~1/2
 1/2	 針穴 φ1.9 歯ピッチ 1.7 1/2	 針穴 φ2.5 歯ピッチ 1.7 1/2			 BOB 1/8~1/2			

[S] ゲージ部品表 (I) LT2-2240  
GAUGE PARTS LIST (I)

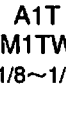
部品コード		Parts No.				
針巾寸法	針板	送り	押工	針ダキ	スベリ板(左)	スベリ板(右)
Gauge Size	Needle Plate	Feed Dog	Presser Foot	Needle Clamp	Slide Plate (L)	Slide Plate (R)
<b>TYPE MOB</b>						
1/8 (3.2mm)	MN10J4101	MN10J4104	MN10J4105	MN57J3102	MN70A1473	MN70A1474
3/16 (4.8mm)	MN10J6101	MN10J6104	MN10J6105	MN57J5102	MN70A1473	MN70A1474
1/4 (6.5mm)	MN10J8101	MN10J8104	MN70J3105	MN57J7102	MN70A1473	MN70A1474
5/16 (8mm)	MN10J9101	MN10J9104	MN10J9105	MN57J9102	MN70A2473	MN70A1474
3/8 (9.5mm)	MN10K1101	MN10K1104	MN10K1105	MN57K1102	MN70A2473	MN70A1474
1/2 (12.7mm)	MN10K3101	MN10K3104	MN10K3105	MN57K3102	MN70A3473	MN70A1474
<b>TYPE BOB</b>						
1/8 (3.2mm)	MN26J4101	MN12J4104	MN26J4105	MN57J3102	MN70A1473	MN70A1474
3/16 (4.8mm)	MN26J6101	MN26J6104	MN26J6105	MN57J5102	MN70A1473	MN70A1474
1/4 (6.5mm)	MN26J8101	MN26J8104	MN69E0105	MN57J7102	MN70A1473	MN70A1474
5/16 (8mm)	MN26J9101	MN26J9104	MN26J9105	MN57J9102	MN70A2473	MN70A1474
3/8 (9.5mm)	MN26K1101	MN26K1104	MN26K1105	MN57K1102	MN70A2473	MN70A1474
1/2 (12.7mm)	MN26K3101	MN12K3104	MN26K3105	MN57K3102	MN70A3473	MN70A1474
<b>オプション L仕様 (薄物用)</b>						
1/8 (3.2mm)	—	MN70J2104	—	—	—	—
3/16 (4.8mm)	—	MN70J4104	—	—	—	—
1/4 (6.5mm)	—	MN70J6104	—	—	—	—
5/16 (8mm)	—	MN70J8104	—	—	—	—
3/8 (9.5mm)	—	MN70J9104	—	—	—	—

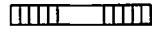
注) オプション L仕様 (薄物用) の — 欄はTYPE MOB相当品を御使用下さい。

☐ ゲージ部品表(Ⅱ) LT2-2250  
GAUGE PARTS LIST (Ⅱ)

針板 Needle Plate			送り Feed Dog				押工 Presser Foot	針ダキ Needle Clamp	スベリ板(左) Slide Plate (L)	スベリ板(右) Slide Plate (R)			
M1TW	A1T	B1T	M1TW	A1T M1TW (デニム用 Denim)	B1T	オプション L仕様 (薄物用)							
 1/8	 針穴 φ1.8 歯ピッチ 1.7 1/8	 針穴 1.8×2.8 歯ピッチ 1.7 1/8	 針穴 2×3.2 歯ピッチ 1.7 1/8	 針穴 φ1.6 歯ピッチ 1.15 1/8	 A1T M1TW 1/8~1/2	 B1T 1/8~1/2	 1/8~1/2	 1/8~1/2	 1/8~1/2				
 3/16~3/8	 針穴 φ1.8 歯ピッチ 1.7 3/16~3/8	 針穴 1.8×2.8 歯ピッチ 1.7 3/16~3/8	 針穴 2.2×3.2 歯ピッチ 1.7 3/16~3/8	 針穴 φ1.6 歯ピッチ 1.15 3/16~3/8						 A1T M1TW 1/8~1/2	 B1T 1/8~1/2	 1/8~1/2	Fig.L135 植え込みボルト Connecting Bolt  1/8~1/2 M95004023
 1/2	 針穴 φ1.8 歯ピッチ 1.7 1/2	 針穴 1.8×2.8 歯ピッチ 1.7 1/2	 針穴 2.2×3.2 歯ピッチ 1.7 1/2										

[T] ゲージ部品表(Ⅱ)LT2-2250  
GAUGE PARTS LIST(Ⅱ)

部品コード		Parts No.					
針巾寸法	針板	送り	送り(デニム)	押エ	針ダキ	スベリ板(左)	スベリ板(右)
Gauge Size	Needle Plate	Feed Dog	(for Denim) Feed Dog	Presser Foot	Needle Clamp	(L) Slide Plate	(R) Slide Plate
<b>TYPE MITW</b>							
1/8 (3.2mm)	MN50J4101	MN50J4104	MN60J4104	MN10J4105	MN57J3102	MN50A0473	MN72A1474
3/16 (4.8mm)	MN50H6101	MN50H6104	MN51H6104	MN10J6105	MN57J5102	MN50A0473	MN72A1474
1/4 (6.5mm)	MN50J8101	MN50J8104	MN51J8104	MN70J3105	MN57J7102	MN50A0473	MN72A1474
5/16 (8mm)	MN50J9101	MN50J9104	MN51J9104	MN10J9105	MN25J9102	MN50A1473	MN72A1474
3/8 (9.5mm)	MN50K1101	MN50K1104	MN51K1104	MN10K1105	MN57K1102	MN50A1473	MN72A1474
1/2 (12.7mm)	MN50K3101	MN50K3104	MN51K3104	MN10K3105	MN57K3102	MN50A2473	MN72A1474
<b>TYPE A1T</b>							
1/8 (3.2mm)	MN52J4101	MN52J4104	—	MN26J4105	MN57J3102	MN50A0473	MN72A1474
3/16 (4.8mm)	MN52H6101	MN52H6104	—	MN26J6105	MN57J5102	MN50A0473	MN72A1474
1/4 (6.5mm)	MN52J8101	MN52J8104	—	MN70J3105	MN57J7102	MN50A0473	MN72A1474
5/16 (8mm)	MN52J9101	MN52J9104	—	MN26J9105	MN57J9102	MN50A1473	MN72A1474
3/8 (9.5mm)	MN52K1101	MN52K1104	—	MN26K1105	MN57K1102	MN50A1473	MN72A1474
1/2 (12.7mm)	MN52K3101	MN52K3104	—	MN26K3105	MN57K3102	MN50A2473	MN72A1474
<b>TYPE B1T</b>							
1/8 (3.2mm)	MN52J4101	MN52J4104	—	MN26J4105	MN57J3102	MN50A0473	MN72A1474
3/16 (4.8mm)	MN52H6101	MN52H6104	—	MN26J6105	MN57J5102	MN50A0473	MN72A1474
1/4 (6.5mm)	MN52J8101	MN52J8104	—	MN69E0105	MN57J7102	MN50A0473	MN72A1474
5/16 (8mm)	MN52J9101	MN52J9104	—	MN26J9105	MN57J9102	MN50A1473	MN72A1474
3/8 (9.5mm)	MN52K1101	MN52K1104	—	MN26K1105	MN57K1102	MN50A1473	MN72A1474
1/2 (12.7mm)	MN52K3101	MN52K3104	—	MN26K3105	MN57K3102	MN50A2473	MN72A1474
<b>オプション L仕様(薄物用)</b>							
1/8 (3.2mm)	—	MN72J2104	—	—	—	—	—
3/16 (4.8mm)	—	MN72J4104	—	—	—	—	—
1/4 (6.5mm)	—	MN72J6104	—	—	—	—	—
5/16 (8mm)	—	MN72J7104	—	—	—	—	—
3/8 (9.5mm)	—	MN72J8104	—	—	—	—	—

注) オプション L仕様(薄物用)の — 欄はTYPE MITW相当品を御使用下さい。

# 索引 (I) INDEX (I)

部品コード Parts. No.	ページ Page	Fig. No.	部品コード Parts. No.	ページ Page	Fig. No.	部品コード Parts. No.	ページ Page	Fig. No.	部品コード Parts. No.	ページ Page	Fig. No.
M90103053	P29	P102	M90825002	P25	M131	M91102002	P17	H112	M91304080	P03	A101
M90107024	P13	F127	M90851015	P09	D131	M91102002	P25	M139	M91305080	P03	A115
M90202060	P07	C123	M90872045	P29	P101	M91103016	P25	M142	M91372045	P15	G106
M90203060	P07	C126	M90879045	P19	J148	M91103045	P15	G110	M91373045	P25	M109
M90208061	P03	A139	M90901001	P13	F149	M91106003	P29	P109	M91373045	P25	M148
M90214063	P13	F145	M90901020	P13	F121	M91106004	P03	A109	M91374045	P23	L136
M90304053	P31	Q115	M90901045	P07	C111	M91106004	P05	B110	M91377045	P23	L134
M90308037	P29	P121	M90902011	P19	J125	M91106004	P07	C110	M91402010	P31	Q109
M90309064	P13	F108	M90902015	P05	B104	M91106004	P15	G127	M91501007	P09	D120
M90312050	P29	P103	M90902015	P07	C101	M91106004	P17	H118	M91501045	P33	R135
M90317063	P15	G139	M90903002	P15	G104	M91106004	P25	M106	M91502002	P09	D118
M90319063	P15	G135	M90903002	P31	Q114	M91106004	P27	N135	M91502002	P09	D125
M90320065	P19	J107	M90903010	P03	A127	M91106004	P31	Q101	M91502002	P11	E104
M90330065	P27	N108	M90903010	P23	L106	M91106011	P03	A129	M91502004	P03	A108
M90350037	P33	R146	M90904011	P03	A107	M91106022	P23	L102	M91502022	P27	N133
M90401050	P07	C113	M90904060	P17	H105	M91107002	P31	Q118	M91502045	P27	N124
M90401050	P21	K116	M90905003	P31	Q130	M91107045	P25	M126	M91503001	P13	F102
M90401053	P29	P117	M90906002	P05	B106	M91108001	P03	A140	M91503001	P21	K130
M90401061	P11	E114	M90906002	P07	C106	M91108001	P09	D141	M91503031	P09	D110
M90402064	P15	G112	M90906002	P31	Q133	M91108001	P15	G107	M91503050	P11	E115
M90403050	P29	P104	M90906010	P23	L121	M91109002	P19	J109	M91505002	P17	H111
M90404060	P15	G125	M90906033	P15	G130	M91109002	P25	M138	M91505007	P17	H103
M90409041	P33	R106	M90907010	P23	L104	M91109002	P29	P105	M91506001	P27	N118
M90421050	P27	N136	M90909003	P05	B120	M91109004	P03	A135	M91506002	P19	J119
M90450050	P13	F128	M90909003	P07	C136	M91109004	P27	N101	M91508004	P33	R117
M90501045	P13	F140	M90910003	P03	A132	M91109004	P29	P120	M91508022	P23	L126
M90501053	P21	K113	M90910003	P05	B142	M91109004	P31	Q120	M91509002	P21	K102
M90502047	P13	F141	M90910003	P07	C138	M91109004	P33	R116	M91509022	P23	L139
M90504065	P15	G123	M90910003	P21	K115	M91110002	P25	M101	M91513001	P09	D115
M90505065	P05	B108	M90911030	P23	L101	M91111001	P31	Q121	M91513001	P09	D133
M90505065	P07	C108	M90915003	P05	B130	M91111004	P27	N103	M91513001	P19	J117
M90507065	P13	F109	M90915003	P13	F103	M91111015	P25	M121	M91515002	P09	D127
M90509060	P11	E112	M90920002	P03	A125	M91111030	P25	M154	M91516001	P09	D106
M90511050	P33	R107	M90920002	P05	B145	M91111033	P23	L138	M91516001	P19	J118
M90515065	P33	R138	M90920002	P07	C129	M91111033	P25	M140	M91516002	P09	D123
M90516060	P05	B144	M90927015	P05	B104	M91112002	P25	M145	M91516002	P17	H102
M90516060	P07	C131	M90927015	P07	C104	M91112015	P25	M105	M91516002	P17	H114
M90518063	P15	G120	M90928015	P05	B140	M91113002	P03	A137	M91516002	P25	M113
M90521060	P05	B144	M90929015	P29	P112	M91113002	P15	G116	M91516015	P27	N121
M90521060	P07	C131	M90930016	P07	C134	M91116002	P03	A116	M91516022	P19	J145
M90550050	P23	L129	M90939002	P11	E110	M91117002	P29	P115	M91517015	P27	N125
M90551050	P21	K125	M90944002	P23	L109	M91118002	P31	Q146	M91519002	P27	N119
M90551050	P29	P128	M90944003	P13	F117	M91118004	P03	A141	M91520001	P33	R136
M90601053	P27	N130	M90944003	P31	Q128	M91131015	P25	M125	M91520002	P27	N116
M90603003	P07	C124	M90952003	P03	A130	M91134015	P23	L124	M91571045	P27	N131
M90603064	P31	Q108	M90974002	P13	F115	M91201011	P03	A102	M91601003	P03	A120
M90605002	P23	L111	M91000085	P17	H126	M91201020	P21	K120	M91601045	P19	J116
M90613011	P13	F118	M91001020	P25	M133	M91201022	P23	L130	M91602001	P09	D102
M90631050	P19	J146	M91002045	P29	P116	M91201045	P25	M129	M91602001	P19	J121
M90701099	P33	R128	M91002045	P33	R120	M91203002	P19	J153	M91602001	P19	J137
M90704060	P15	G133	M91004067	P25	M159	M91204003	P19	J141	M91602001	P21	K123
M90704065	P29	P130	M91005067	P25	M160	M91206030	P21	K127	M91602003	P25	M158
M90801010	P23	L108	M91018099	P27	N138	M91206045	P21	K128	M91602015	P19	J110
M90802001	P05	B133	M91019099	P29	P133	M91209002	P17	H127	M91602020	P25	M116
M90802001	P13	F131	M91055020	P25	M118	M91215002	P17	H119	M91603001	P19	J105
M90803020	P19	J152	M91075004	P33	R118	M91219015	P09	D109	M91603003	P11	E118
M90804003	P19	J151	M91101015	P15	G101	M91231015	P25	M127	M91603003	P19	J130
M90805002	P31	Q127	M91101045	P05	B113	M91251015	P25	M110	M91603003	P19	J134
M90806001	P13	F132	M91101045	P07	C111	M91252045	P21	K114	M91603003	P25	M151
M90806002	P29	P127	M91101045	P25	M146	M91260030	P21	K110	M91603046	P07	C119
M90816002	P25	M161	M91101045	P27	N126	M91271015	P23	L132	M91606001	P09	D103
M90819063	P19	J132	M91101046	P05	B118	M91301001	P03	A121	M91606001	P21	K131

# 索引 (Ⅱ) INDEX (Ⅱ)

部品コード Parts. No.	ページ Page	Fig. No.	部品コード Parts. No.	ページ Page	Fig. No.	部品コード Parts. No.	ページ Page	Fig. No.	部品コード Parts. No.	ページ Page	Fig. No.								
M91609046	.....	P07	.....	C116	MF01A0259	.....	P27	.....	N110	MN10A1456	.....	P27	.....	N107	MN50A2601	.....	P27	.....	N129
M91610046	.....	P05	.....	B125	MF01A0476	.....	P27	.....	N113	MN10A1555	.....	P07	.....	C133	MN50A2910	.....	P27	.....	N132
M91611046	.....	P05	.....	B128	MF01A0565	.....	P33	.....	R114	MN10A1572	.....	P07	.....	C139	MN50A3454	.....	P25	.....	M134
M91652002	.....	P21	.....	K126	MF01A0631	.....	P17	.....	H122	MN10A1851	.....	P09	.....	D117	MN50A3572	.....	P25	.....	M155
M91655001	.....	P21	.....	K132	MF01A1476	.....	P27	.....	N111	MN10A3245	.....	P05	.....	B123	MN50A3601	.....	P25	.....	M147
M91658002	.....	P21	.....	K135	MF01E0418	.....	P33	.....	R129	MN10A3245	.....	P07	.....	C120	MN50A3950	.....	P25	.....	M141
M91801002	.....	P09	.....	D104	MF02A0245	.....	P17	.....	H124	MN10A4742	.....	P03	.....	A118	MN50A4572	.....	P05	.....	B111
M91802006	.....	P09	.....	D105	MF10A0148	.....	P21	.....	K108	MN10A6740	.....	P09	.....	D108	MN50A4572	.....	P07	.....	C118
M92001015	.....	P11	.....	E121	MF10A0245	.....	P07	.....	C120	MN10E0175	.....	P07	.....	C125	MN50A4950	.....	P27	.....	N102
M92002002	.....	P33	.....	R126	MF10A0555	.....	P05	.....	B126	MN10E0301	.....	P21	.....	K901	MN50A5228	.....	P27	.....	N134
M92002030	.....	P15	.....	G137	MF10A0689	.....	P25	.....	M156	MN12B0123	.....	P21	.....	K105	MN50A5742	.....	P03	.....	A126
M92002045	.....	P11	.....	E120	MF10A0689	.....	P31	.....	Q116	MN12B0123	.....	P33	.....	R105	MN50A6228	.....	P17	.....	H110
M92003020	.....	P15	.....	G109	MF10A1553	.....	P07	.....	C112	MN25A0161	.....	P13	.....	F122	MN50A6601	.....	P05	.....	B107
M92005031	.....	P33	.....	R134	MF10A1555	.....	P05	.....	B116	MN25A0192	.....	P13	.....	F104	MN50A6601	.....	P07	.....	C107
M92512045	.....	P03	.....	A113	MF10A2572	.....	P17	.....	H107	MN25A0411	.....	P13	.....	F138	MN50E0220	.....	P05	.....	B102
M93001050	.....	P27	.....	N109	MF10E0148	.....	P19	.....	J143	MN25A0426	.....	P13	.....	F119	MN50E0220	.....	P07	.....	C102
M93002050	.....	P13	.....	F114	MF10E2148	.....	P11	.....	E101	MN25A0476	.....	P13	.....	F124	MN50E0742	.....	P31	.....	Q136
M93002050	.....	P17	.....	H133	MF10E2148	.....	P11	.....	E122	MN25A0479	.....	P33	.....	R141	MN52A0245	.....	P21	.....	K106
M93002050	.....	P27	.....	N117	MF10E2148	.....	P21	.....	K134	MN25A0482	.....	P13	.....	F143	MN52A0300	.....	P21	.....	K117
M93003020	.....	P23	.....	L114	MF10E3148	.....	P13	.....	F105	MN25A0601	.....	P15	.....	G128	MN52A0301	.....	P21	.....	K112
M93003099	.....	P29	.....	P135	MF10E3148	.....	P19	.....	J133	MN25A0671	.....	P11	.....	E123	MN52A1245	.....	P05	.....	B123
M93004052	.....	P15	.....	G134	MF11D0245	.....	P05	.....	B123	MN25A0833	.....	P13	.....	F126	MN52A1245	.....	P07	.....	C120
M93005050	.....	P21	.....	K129	MF11D0245	.....	P07	.....	C120	MN25A1477	.....	P13	.....	F113	MN55A0120	.....	P21	.....	K104
M93006020	.....	P19	.....	J147	MF20A0703	.....	P09	.....	D143	MN25A1572	.....	P13	.....	F144	MN55A0125	.....	P21	.....	K107
M93220035	.....	P09	.....	D144	MF20A1723	.....	P33	.....	R132	MN25A1665	.....	P13	.....	F120	MN55A0148	.....	P13	.....	F106
M94003099	.....	P25	.....	M112	MF20A1729	.....	P33	.....	R133	MN25A2572	.....	P13	.....	F134	MN55A0750	.....	P11	.....	E111
M94003099	.....	P27	.....	N104	MF36A0750	.....	P25	.....	M130	MN25A2665	.....	P13	.....	F123	MN55A0950	.....	P15	.....	G124
M94004030	.....	P13	.....	F146	MF40A1780	.....	P31	.....	Q148	MN25A4572	.....	P15	.....	G122	MN55A1956	.....	P11	.....	E109
M95001037	.....	P25	.....	M152	MF40E2484	.....	P29	.....	P123	MN40A0123	.....	P21	.....	K105	MN55A2672	.....	P11	.....	E119
M95002063	.....	P13	.....	F136	MF60A0137	.....	P33	.....	R110	MN40A0123	.....	P33	.....	R105	MN57A0120	.....	P21	.....	K104
M95003053	.....	P17	.....	H113	MF70A0286	.....	P19	.....	J140	MN40A0154	.....	P17	.....	H117	MN57A0125	.....	P21	.....	K107
M95003063	.....	P13	.....	F142	MF70A0689	.....	P31	.....	Q102	MN40A0180	.....	P03	.....	A117	MN60A0125	.....	P21	.....	K107
M95004021	.....	P19	.....	J127	MF80A0352	.....	P19	.....	J136	MN40A0278	.....	P19	.....	J142	MN60A0154	.....	P15	.....	G132
M95004023	.....	P23	.....	L135	MF80A0780	.....	P19	.....	J144	MN40A0491	.....	P19	.....	J138	MN60A0172	.....	P25	.....	M102
M95004067	.....	P09	.....	D114	MF80A0852	.....	P17	.....	H108	MN40A0572	.....	P17	.....	H116	MN60A0173	.....	P25	.....	M104
M95005023	.....	P15	.....	G105	MF85A1631	.....	P17	.....	H128	MN40A0578	.....	P33	.....	R142	MN60A0279	.....	P19	.....	J131
M95007063	.....	P31	.....	Q124	MF90A0640	.....	P17	.....	H125	MN40A0669	.....	P11	.....	E116	MN60A0411	.....	P23	.....	L116
M95007067	.....	P25	.....	M119	MG50A0285	.....	P19	.....	J135	MN40A0705	.....	P31	.....	Q126	MN60A0454	.....	P25	.....	M135
M95008020	.....	P17	.....	H137	MG68A0366	.....	P27	.....	N137	MN40A0750	.....	P31	.....	Q122	MN60A0572	.....	P15	.....	G138
M95014021	.....	P17	.....	H130	MN11A0556	.....	P05	.....	B122	MN40A1139	.....	P33	.....	R125	MN60A0620	.....	P25	.....	M111
M97001052	.....	P33	.....	R127	MN10A0131	.....	P03	.....	A105	MN40A1572	.....	P31	.....	Q125	MN60A0620	.....	P27	.....	N104
M97003035	.....	P03	.....	A112	MN10A0155	.....	P07	.....	C132	MN40A1750	.....	P09	.....	D122	MN60A0678	.....	P15	.....	G114
M97003095	.....	P27	.....	N105	MN10A0172	.....	P33	.....	R113	MN40E0301	.....	P21	.....	K901	MN60A0836	.....	P23	.....	L122
M97008060	.....	P05	.....	B127	MN10A0187	.....	P07	.....	C127	MN40E0727	.....	P33	.....	R131	MN60A0837	.....	P23	.....	L120
M97009060	.....	P05	.....	B143	MN10A0220	.....	P07	.....	C102	MN42A0128	.....	P33	.....	R101	MN60A0886	.....	P25	.....	M132
M97357099	.....	P29	.....	P134	MN10A0301	.....	P21	.....	K112	MN50A0245	.....	P21	.....	K106	MN60A0950	.....	P23	.....	L901
M98001070	.....	P13	.....	F137	MN10A0302	.....	P21	.....	K109	MN50A0278	.....	P19	.....	J142	MN60A1155	.....	P15	.....	G140
M98005022	.....	P27	.....	N128	MN10A0340	.....	P21	.....	K111	MN50A0300	.....	P21	.....	K117	MN60A1228	.....	P23	.....	L131
M99083063	.....	P15	.....	G118	MN10A0476	.....	P03	.....	A103	MN50A0350	.....	P25	.....	M115	MN60A1742	.....	P23	.....	L123
MB02A0608	.....	P33	.....	R111	MN10A0477	.....	P05	.....	B146	MN50A0411	.....	P25	.....	M124	MN60A2228	.....	P23	.....	L131
MB02A1608	.....	P33	.....	R112	MN10A0477	.....	P07	.....	C130	MN50A0417	.....	P27	.....	N122	MN60A2742	.....	P23	.....	L118
MB60A1620	.....	P27	.....	N106	MN10A0500	.....	P11	.....	E106	MN50A0426	.....	P03	.....	A119	MN60A3228	.....	P23	.....	L127
MB62A0975	.....	P15	.....	G102	MN10A0523	.....	P09	.....	D126	MN50A0477	.....	P25	.....	M137	MN60A3572	.....	P15	.....	G126
MB62A0975	.....	P23	.....	L133	MN10A0554	.....	P07	.....	C128	MN50A0555	.....	P07	.....	C114	MN60A4572	.....	P15	.....	G136
ME10E1776	.....	P33	.....	R121	MN10A0555	.....	P07	.....	C122	MN50A0746	.....	P25	.....	M157	MN60A5572	.....	P25	.....	M122
ME20A0406	.....	P27	.....	N903	MN10A0556	.....	P07	.....	C121	MN50A0780	.....	P25	.....	M150	MN60A6572	.....	P25	.....	M103
MF00A0257	.....	P17	.....	H120	MN10A0588	.....	P11	.....	E105	MN50A0839	.....	P23	.....	L103	MN60E0120	.....	P21	.....	K104
MF00A0267	.....	P09	.....	D132	MN10A0740	.....	P13	.....	F147	MN50A0910	.....	P23	.....	L128	MN60E0746	.....	P25	.....	M107
MF00A0608	.....	P33	.....	R130	MN10A0851	.....	P05	.....	B103	MN50A1123	.....	P21	.....	K105	MN60E0950	.....	P25	.....	M123
MF00A0852	.....	P17	.....	H109	MN10A0851	.....	P07	.....	C103	MN50A1123	.....	P33	.....	R105	MN62A0123	.....	P21	.....	K105
MF00A0950	.....	P17	.....	H123	MN10A1128	.....	P13	.....	F130	MN50A1411	.....	P25	.....	M162	MN62A0123	.....	P33	.....	R105
MF00A1780	.....	P29	.....	P124	MN10A1456	.....	P09	.....	D121	MN50A2572	.....	P29	.....	P111	MN62A0125	.....	P21	.....	K107



# 索引 (Ⅲ) INDEX (Ⅲ)

部品コード Parts. No.	ページ Page	Fig. No.	部品コード Parts. No.	ページ Page	Fig. No.	部品コード Parts. No.	ページ Page	Fig. No.	部品コード Parts. No.	ページ Page	Fig. No.
MN62E0120	P21	K104	MN70A1419	P33	R109	MN72A0477	P29	P118	MN80A1688	P15	G117
MN69A0181	P05	B119	MN70A1472	P03	A122	MN72A0601	P25	M108	MN80A1750	P15	G113
MN69A0181	P07	C135	MN70A1553	P05	B114	MN72A0632	P17	H115	MN80A1780	P13	F112
MN69A0342	P21	K118	MN70A1740	P19	J150	MN72A0742	P03	A128	MN80E0383	P09	D101
MN69A0344	P21	K133	MN70A1780	P31	Q117	MN72A0750	P25	M114	MN80E0582	P11	E901
MN69A0345	P21	K101	MN70A2181	P05	B121	MN72A0768	P09	D128	MN80E0666	P13	F901
MN69A0476	P21	K119	MN70A2181	P07	C137	MN72A0910	P29	P113	MN80E0775	P15	G901
MN69A0631	P17	H128	MN70A2252	P09	D140	MN72A0950	P05	B105	MN81A0721	P09	D116
MN69A0744	P19	J149	MN70A2456	P19	J123	MN72A0950	P07	C105	MN81E0582	P11	E901
MN69E0190	P33	R124	MN70A2750	P21	K103	MN72A0975	P23	L137	MN82A0154	P23	L115
MN69E0210	P05	B901	MN70A2780	P31	Q119	MN72A0981	P29	P114	MN82A0180	P33	R145
MN69E0290	P19	J901	MN70A2956	P17	H104	MN72A0982	P29	P108	MN82A0192	P23	L110
MN69E1210	P07	C901	MN70A3688	P31	Q103	MN72A1252	P09	D138	MN82A0230	P09	D129
MN70A0154	P05	B132	MN70A3750	P19	J122	MN72A1454	P29	P131	MN82A0259	P09	D142
MN70A0181	P03	A106	MN70A5776	P33	R115	MN72A1601	P25	M128	MN82A0345	P21	K101
MN70A0187	P05	B138	MN70A5780	P31	Q142	MN72A1694	P27	N112	MN82A0551	P23	L113
MN70A0232	P09	D107	MN70A8780	P31	Q143	MN72A1750	P25	M153	MN82A0694	P27	N114
MN70A0237	P03	A114	MN70A9780	P31	Q149	MN72A1776	P33	R121	MN82A0841	P17	H121
MN70A0245	P05	B117	MN70E0138	P31	Q107	MN72A1950	P27	N120	MN82A1154	P23	L119
MN70A0252	P09	D111	MN70E0139	P33	R902	MN72A2601	P29	P122	MN82A1192	P23	L112
MN70A0253	P09	D139	MN70E0139	P33	R902	MN72A4980	P29	P132	MN82E0534	P27	N901
MN70A0257	P17	H132	MN70E0148	P19	J128	MN72E0210	P05	B901	MN83A0345	P21	K101
MN70A0262	P09	D130	MN70E0148	P31	Q139	MN72E0327	P29	P106	MN83E0210	P07	C902
MN70A0265	P09	D134	MN70E0149	P33	R122	MN72E0601	P07	C109	MN84E0210	P05	B901
MN70A0273	P19	J120	MN70E0175	P05	B139	MN72E0682	P27	N902	MN85A0325	P13	F148
MN70A0291	P17	H101	MN70E0181	P03	A124	MN72E1210	P07	C902	MP40A0340	P21	K111
MN70A0308	P05	B137	MN70E0190	P33	R124	MN72E1519	P27	N127	MP40A0571	P31	Q144
MN70A0320	P17	H106	MN70E0210	P05	B901	MN72E1682	P27	N115	MP40A2688	P31	Q123
MN70A0321	P17	H134	MN70E0281	P19	J126	MN72E2519	P29	P125	MP40A2740	P19	J139
MN70A0325	P17	H135	MN70E0290	P19	J901	MN72E2776	P33	R901	MP40A3740	P31	Q104
MN70A0343	P21	K124	MN70E0453	P19	J108	MN74A0344	P21	K133	MP40A4689	P31	Q132
MN70A0344	P21	K133	MN70E0601	P07	C109	MN74A0841	P17	H121	MP41A0767	P09	D119
MN70A0345	P21	K101	MN70E0644	P21	K902	MN74E0210	P05	B901	MP41A0838	P23	L105
MN70A0387	P11	E108	MN70E0682	P09	D124	MN74E1210	P07	C902	MP41A1270	P05	B112
MN70A0419	P33	R108	MN70E0688	P31	Q105	MN80A0131	P03	A133	MP41A1270	P07	C117
MN70A0429	P31	Q147	MN70E0740	P33	R140	MN80A0154	P13	F116	MP41B0838	P23	L107
MN70A0450	P19	J103	MN70E0956	P19	J115	MN80A0180	P15	G115	MP43A0910	P23	L125
MN70A0451	P19	J101	MN70E1148	P19	J102	MN80A0228	P15	G108	MP47A1454	P19	J129
MN70A0452	P19	J106	MN70E1175	P05	B135	MN80A0230	P09	D129	MP47A1776	P33	R119
MN70A0476	P21	K119	MN70E1210	P07	C901	MN80A0267	P15	G141	MP48A0281	P19	J126
MN70A0477	P05	B131	MN70E1601	P31	Q131	MN80A0339	P03	A131	MP48E0193	P33	R123
MN70A0510	P09	D135	MN70E1635	P17	H131	MN80A0342	P21	K118	MP60A0148	P11	E107
MN70A0511	P09	D113	MN70E1688	P31	Q106	MN80A0350	P15	G131	MP60A0228	P17	H110
MN70A0553	P05	B115	MN70E2601	P05	B109	MN80A0454	P13	F110	MP60A0337	P31	Q129
MN70A0554	P05	B141	MN70E2776	P33	R901	MN80A0455	P03	A138	MP60A0500	P03	A142
MN70A0572	P09	D112	MN70E3688	P31	Q113	MN80A0477	P13	F133	MP60A0672	P11	E113
MN70A0573	P05	B129	MN70E4688	P31	Q137	MN80A0572	P13	F139	MP60A0761	P17	H129
MN70A0587	P11	E102	MN70E5688	P31	Q138	MN80A0584	P03	A111	MP60A3572	P25	M120
MN70A0632	P17	H115	MN70E6688	P31	Q140	MN80A0601	P15	G121	MP61A0245	P07	C115
MN70A0724	P33	R137	MN70E7688	P31	Q111	MN80A0660	P13	F135	MP61A0729	P27	N123
MN70A0734	P33	R139	MN70E7688	P31	Q134	MN80A0665	P13	F125	MP61E0228	P25	M144
MN70A0738	P09	D137	MN70E7688	P31	Q141	MN80A0666	P13	F107	MP61E0519	P25	M149
MN70A0750	P05	B134	MN70E7688	P31	Q145	MN80A0668	P11	E117	MP66A0603	P25	M136
MN70A0760	P19	J104	MN70E8688	P31	Q112	MN80A0688	P15	G129	MQ60A2780	P31	Q135
MN70A0768	P09	D128	MN72A0320	P17	H106	MN80A0740	P03	A134	MS01A0976	P33	R102
MN70A0771	P19	J124	MN72A0339	P29	P126	MN80A0742	P15	G103	MS01A1976	P33	R144
MN70A0780	P31	Q110	MN72A0344	P21	K133	MN80A0750	P13	F101	MS02A0976	P33	R104
MN70A0880	P03	A110	MN72A0350	P25	M117	MN80A0780	P13	F111	MS02A1976	P33	R103
MN70A1154	P17	H136	MN72A0397	P29	P119	MN80A0830	P03	A136	MS10A0976	P33	R143
MN70A1181	P03	A123	MN72A0454	P29	P107	MN80A1131	P03	A104	MT60A0802	P05	B124
MN70A1187	P05	B136	MN72A0470	P29	P129	MN80A1154	P13	F129	MV01A0128	P13	F130
MN70A1252	P09	D136	MN72A0476	P29	P110	MN80A1454	P15	G111	MV01A0128	P33	R101

## 三菱電機株式会社

お問い合わせは下記へどうぞ

FAシステム事業本部 機器計画部 駆動機器グループ 〒100-8310 東京都千代田区丸の内2-7-3(東京ビル)  
代表電話番号 (03)3218-6631 代表FAX番号 (03)3218-6823

## MITSUBISHI ELECTRIC CORPORATION

FACTORY AUTOMATION SYSTEM GROUP

Tokyo 100-8310, Japan

Fax : +81-3-3218-6821